

SCHEMATIC CIRCUITRY			
SHIELD TERMINAL	MODEL NO.	SCHEMATIC CIRCUITRY	APPLICATIONS
<ul style="list-style-type: none"> Line to SHLD: Floating Earth to SHLD: Floating 	• MD7RB-FFx		<ul style="list-style-type: none"> Standard type To protect a device having isolation between Signal and Earth. When SHLD should be floating against the earth. (single-end grounding)
<ul style="list-style-type: none"> Line to SHLD: Floating Earth to SHLD: Grounding 	• MD7RB-FGx		<ul style="list-style-type: none"> To protect a device having isolation between Signal and Earth. When SHLD should be grounded. (single- or both-end grounding)
<ul style="list-style-type: none"> Line to SHLD: Grounding Earth to SHLD: Floating 	• MD7RB-GFx		<ul style="list-style-type: none"> To protect a device having isolation between Signal and Earth. When SHLD wire should be connected to SG terminal of the protected device. (SHLD is not grounded to the earth.)
<ul style="list-style-type: none"> Line to SHLD: Grounding Earth to SHLD: Grounding 	• MD7RB-GGx		<ul style="list-style-type: none"> To protect a device which does not have a good dielectric strength between Signal and Earth.

Sections enclosed with broken line may differ depending upon the models.

Specifications subject to change without notice.

SELECTING SHIELD TERMINAL TYPE

- The surge protector has a dedicated shield terminal effective for easy shield wiring and surge protection.
- Review the shield method (grounding, non-grounding, connecting to SG, etc.) required by the protected device or system.
- There is no electrical effect to the shield by installing the surge protector, but an appropriate shield terminal type must be selected to suit user applications.
- Refer to the flow chart below to choose.

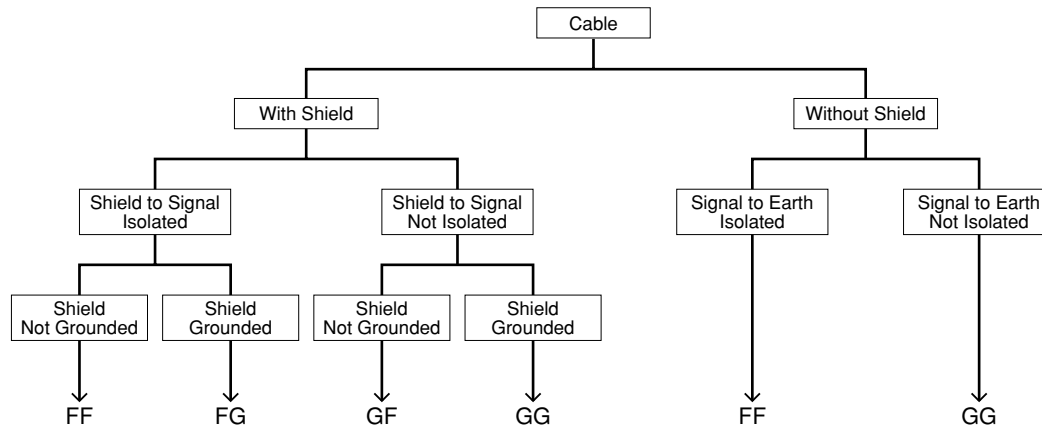

CONNECTION DIAGRAM

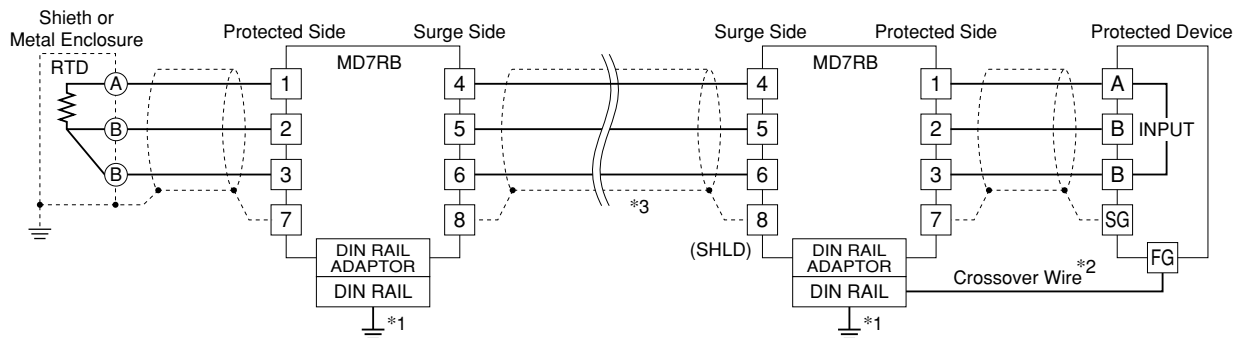

*1. Be sure to ground the DIN rail. Recommended grounding resistance $\leq 100\Omega$

*2. Cross-wire between the DIN rail and the metal housing of the protected device to equalize the earth potential.

Ground only the surge protector when the protected device has no ground terminal.

*3. Shield wiring method is an example. Proceed according to the system requirements.

EXTERNAL DIMENSIONS & TERMINAL ASSIGNMENT (unit: mm)

