

Super-mini Signal Conditioners with LCD Display M7E-UNIT

DC ALARM
(dual or quad alarm trip)

MODEL **M7EASV**

MODEL & SUFFIX CODE SELECTION

M7EASV-□□-□□

MODEL _____
 INPUT _____
Current
Z1 : Range 0 – 50mA DC
Voltage
S1 : Range -1000 – +1000mV DC
S2 : Range -10 – +10V DC
OUTPUT _____
2 : 4 points; N.O. or make contact
3 : 4 points; N.C. or break contact
5 : 2 points; SPDT or transfer contact
POWER INPUT _____
M2 : 100 – 240V AC
R : 24V DC
OPTIONS _____
 /CE: CE marking

ORDERING INFORMATION

Specify code number. (e.g. M7EASV-Z12-M2/CE)

| INPUT CODE | FACTORY SETTING |
|------------|-----------------|
| Z1 | 4 – 20mA DC |
| S1 | 0 – 100mV DC |
| S2 | 1 – 5V DC |

RELATED PRODUCTS

- PC configurator software (model: M7CFG)
Downloadable at M-System's web site:
<http://www.m-system.co.jp>
- PC configurator cable (model: MCN-CON)

GENERAL SPECIFICATIONS

Construction: Plug-in
Connection: M3 screw terminals (torque 0.8 N.m)
Housing material: Flame-resistant resin (black)
Isolation: Input to output to power
Programming: Front control buttons or PC software

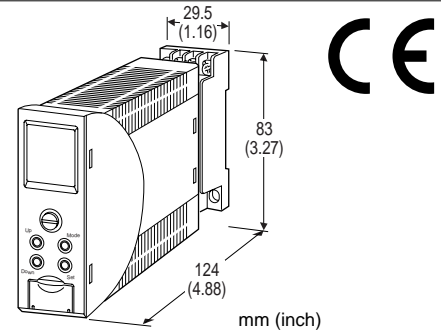

Functions & Features

- Provides relay outputs at preset DC input levels
- Quad or dual trip
- Front LCD display indicating values in scaled engineering unit range is used to program the module
- Adjustable deadband (hysteresis)
- Software lock
- ON delay time selectable
- On-delay timer
- Hi/Lo trip and energized/de-energized coil independently selectable for each setpoint
- Enclosed relays
- Relays can be powered by 200V AC and 100V DC
- High-density mounting on DIN rail

Typical Applications

- Annunciator
- Various alarm applications

Programmable parameters:

- Input range
- Input fine adjustments
- Moving average (None, 4, 8, 16 or 32 samples)
- Scale Range: -9999 to +9999
Unit: User specific unit programmable.
- Decimal point position
- Alarm output (L1...L4 independently)
Setpoint (scaled value)
Trip action (Hi or Lo)
Hysteresis (scaled value)
Relay coil (energized or de-energized)
- Power ON delay time (0 to 99 sec.)
- Alarm ON delay time (0 to 999 sec.)
- Latching or not
- LCD Contrast
Back Light (On, Off, Off timer)
- Tag name
- Alarm test

LCD DISPLAY

Display functions: Displays and sets measured range, engineering unit, alarm operation

Effective visual area: Approx. 15.6 × 18.9 mm (0.61" × 0.74")

Number of pixels: 68 × 95 (horizontal × vertical)

Character color: Black

Backlight: LED (orange in normal status, red when an alarm is tripped.)

Backlight life: Approx. 50,000 hours*

Range: -9999 to +9999

Decimal point position: Selectable

Display rate: 150 milliseconds

LCD type: Transreflective FSTN

*Expected time for the LCD brightness to be reduced by half when the LCD is used continuously in 50% brightness in 25°C.

INPUT

■ **DC CURRENT:** 0 – 50mA DC; 100Ω resistor incorporated (0.5W)

Operational range: 0 – 70mA DC (100Ω/0.5W)

Minimum span: 2mA

Offset: Lower range can be any specific value within the input range provided that the minimum span is maintained.

■ DC VOLTAGE

Code S1 (narrow spans): -1000 – +1000mV DC

Operational range: -1150 – +1150mV DC

Minimum span: 10mV

Code S2 (wide spans): -11.5 – +11.5V DC

Operational range: -10 – +10V DC

Minimum span: 0.1V

Offset: Lower range can be any specific value within the input range provided that the minimum span is maintained.

Input resistance: 1MΩ minimum

OUTPUT

Alarm Trip Operation

Example with quad N.O. contacts (LL, L, H, HH); Terminal No. in parentheses

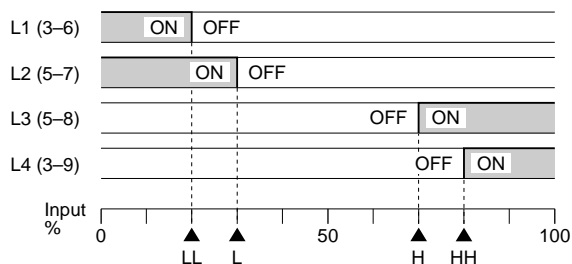

Trip Operation in Power Failure

- **Output Code 2:** All relays turn OFF.
- **Output Code 3:** All relays turn ON.
- **Output Code 5:** Terminals 3 – 9, 5 – 8 turn ON.

■ QUAD ALARM

Relay rating: 120V AC @1A (cosφ=1)

240V AC @0.5A (cosφ=1)

30V DC @1A (resistive load)

electrical life 10⁵ cycles (rate 30/min.)

Maximum switching voltage: 250V AC* or 125V DC

Maximum switching power: 120VA or 30W

Minimum load: 5V DC @10mA

Mechanical life: 5 × 10⁷ cycles

■ DUAL ALARM

Relay rating: 120V AC @4A (cosφ=1)

240V AC @2A (cosφ=1)

30V DC @4A (resistive load)

electrical life 10⁵ cycles (rate 30/min.)

Maximum switching voltage: 250V AC* or 125V DC

Maximum switching power: 480VA or 150W

Minimum load: 5V DC @10mA

Mechanical life: 5 × 10⁷ cycles

*Limited to the max. voltage 125V AC or to the use for Over Voltage Category I in order to conform with EC Directive.

INSTALLATION

Power input

AC: Operational voltage range 85 – 264V AC; 47 – 66 Hz; approx. 4VA at 100V approx. 5VA at 200V approx. 6VA at 264V

DC: Operational voltage range 24V DC ±10%; approx. 3W; ripple 10% p-p max.

Operating temperature: -5 to +55°C (23 to 131°F)

Operating humidity: 30 to 90% RH (non-condensing)

Mounting: Surface or DIN rail

Dimensions: W29.5×H83×D124 mm (1.16"×3.27"×4.88")

Weight: 200 g (0.44 lbs)

PERFORMANCE in percentage of FS input

Setpoint accuracy (trip point accuracy):

$$\pm(0.1\% \text{ of FS} + 1 \text{ digit})$$

Display accuracy: $\pm(0.1\% \text{ of FS} + 1 \text{ digit})$

Temp. coefficient: $\pm 0.015\%/^{\circ}\text{C}$ ($\pm 0.008\%/^{\circ}\text{F}$)

Response time: ≤ 0.5 seconds (0 – 100% at 90% setpoint)

Line voltage effect: $\pm 0.1\%$ over voltage range

Insulation resistance: $\geq 100\text{M}\Omega$ with 500V DC

Dielectric strength: 2000V AC @1 minute

(input to output to power to ground)

STANDARDS & APPROVALS

CE conformity: EMC Directive (89/336/EEC)

EMI EN61000-6-4

EMS EN61000-6-2

Low Voltage Directive (2006/95/EC)

EN61010-1

Installation category II

Pollution degree 2

Max. operating voltage 300V

Input or output to power – Reinforced insulation

Input to output – Basic insulation

SCHEMATIC CIRCUITRY & CONNECTION DIAGRAM

OUTPUT CODE 2: N.O. Relay

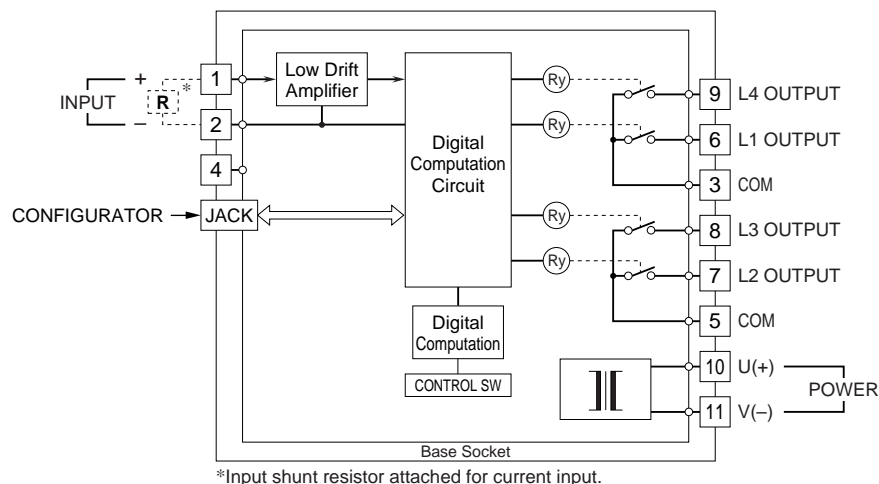

OUTPUT CODE 3: N.C. Relay

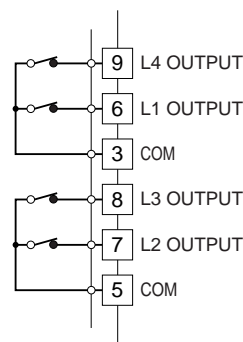

OUTPUT CODE 5: SPDT Relay

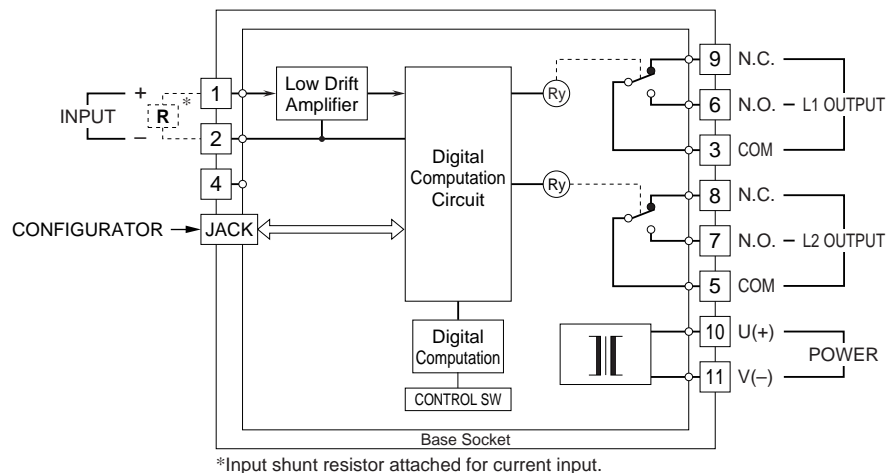

Relay Protection

AC Powered

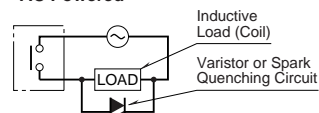

DC Powered

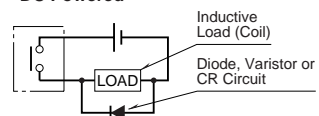

FRONT PANEL CONFIGURATION

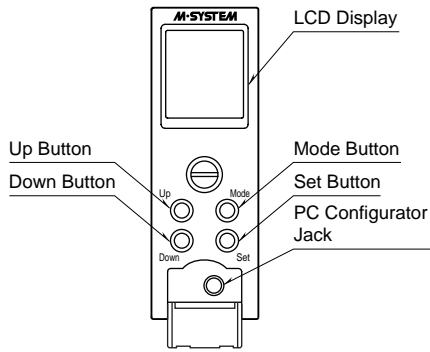

PROGRAMMING

Two ways of configuring the M7EASV are available:

1. PC CONFIGURATION

Windows compatible PC Configurator Software (model: M7CFG) is available. For detailed information, please refer to the users manual for the M7CFG.

2. FRONT CONTROL BUTTONS

■ BASIC OPERATION

The M7EASV has four control buttons equipped on the front panel. Using these buttons, various parameters can be programmed. For detailed information, please refer to the instruction manual for the M7EASV.

Functions of each button are as follows:

- MODE:** Used to turn the module to the Set Up Mode or to move from one parameter to another. Whenever the MODE button is pressed, the relevant setting is saved. Press the MODE button at least for 2 seconds to turn the module into 'Programmable' mode. The module returns to the Monitor Mode when the MODE button is pressed for at least 2 seconds.
- SET:** Used to enable a selected command or selection/value and to shift the cursor position to a next line.
- UP:** Used to shift the cursor position to a next selection or to increase a displayed value.
- DOWN:** Used to shift the cursor position to a previous selection or to decrease a displayed value.

■ FLOWCHART

See Figure 1.

EXTERNAL DIMENSIONS & TERMINAL ASSIGNMENTS mm (inch)

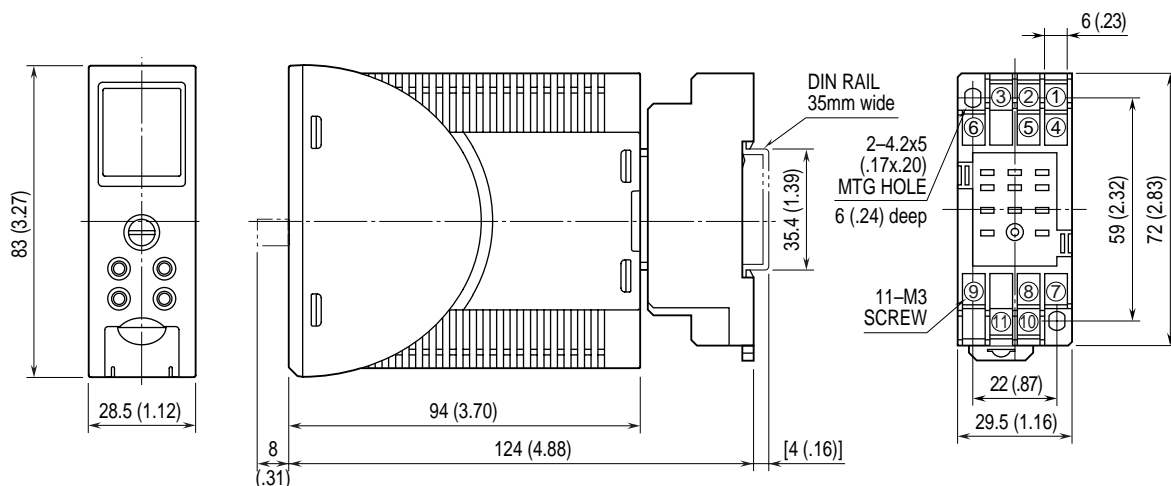

•When mounting, no extra space is needed between units.

Figure 1

