

Dual Output Plug-in Signal Conditioners W-UNIT

PULSE ISOLATOR
(built-in excitation)

MODEL **WYPD**

MODEL & SUFFIX CODE SELECTION

WYPD-□□□□□□□□

MODEL _____
 INPUT _____
A : Dry contact
B : Voltage pulse (Specify sensitivity)
C : 5V pulse (sensitivity 2V)
D : 12V/24V pulse (sensitivity 5V)
H : Two-wire current pulse
EXCITATION _____
1 : 5V DC @80mA
4 : 12V DC @40mA
OUTPUT 1 _____
A1 : Open collector (max. frequency 100 kHz)
A2 : Open collector (max. frequency 10 Hz)
M1 : 5V pulse (max. frequency 100 kHz)
M2 : 5V pulse (max. frequency 10 Hz)
N1 : 12V pulse (max. frequency 100 kHz)
N2 : 12V pulse (max. frequency 10 Hz)
H : Relay contact (max. frequency 0.5 Hz)
OUTPUT 2 _____
 Same availability as Output 1.
OUTPUT PULSE WIDTH _____
1 : Equal to the input
2 : One-shot output* (≤30 ms; std. pulse width 5 ms)
3 : One-shot output* (≥30 ms; std. pulse width 50 ms)
 *Specify when optional pulse width is required.
OUTPUT LOGIC _____
N : The same as the input
R : Inverted
POWER INPUT _____

AC Power		DC Power	
B : 100V AC	G : 200V AC	S : 12V DC	
C : 110V AC	H : 220V AC	R : 24V DC	
D : 115V AC	J : 240V AC	V : 48V DC	
F : 120V AC			

Remark 1: Choose a combination of output 1 and 2 with same max. frequency limit.
 Remark 2: Output logic of open collector is reversed when open collector and others are mixed.

ORDERING INFORMATION

Specify code number and variables. Use Ordering Information Sheet (No. ESU-2276). Default setting will be used if not otherwise specified.

- Code number (e.g. WYPD-D4A2M23N-B)
- Frequency range (e.g. 0 – 5 Hz)
- Output pulse width (e.g. 75 msec.)

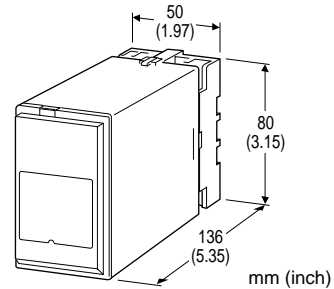

Functions & Features

- Galvanically isolating pulse rate signals
- Input frequency = output frequency
- Various outputs (relay, open collector and voltage pulses)
- Excitation
- Isolation up to 2000V AC
- High-density mounting

Typical Applications

- Isolating field pulse signals in order to reduce noises
- Changing e.g. dry contact signal to e.g. 5V signals

GENERAL SPECIFICATIONS

Construction: plug-in
Connection: M3.5 screw terminals
Housing material: flame-resistant resin (black)
Isolation: input to output 1 to output 2 to power
Input pulse sensing: DC coupled
Input filter: provided for 10 Hz or lower output frequency (time constant approx. 1 msec.)

INPUT & OUTPUT

■INPUT
Max. frequency: 100 kHz
Excitation: shortcircuit protection; approx. 150mA at shortcircuit
Pulse width time requirement: 5 μsec. min. (10 ms for 0 – 10 Hz or lower frequency)

•Dry Contact
Sensing: 10V DC @2.5mA
ON/OFF level: ≥5.5kΩ/5.5V for OFF;
 ≤1.8kΩ/4.5V for ON

• **Voltage Pulse:** Specify DC offset and amplitude.

Waveform: square or sine

Input impedance: 10kΩ minimum

Input amplitude: 2 – 50V p-p

Offset: 2 – 10V

Max. voltage between input terminals: 50V

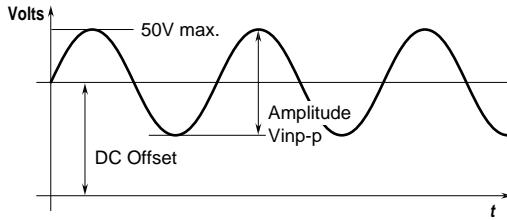

• **5V, 12V, 24V Pulse**

Waveform: square or sine

Input impedance: 10kΩ minimum

Detecting level

INPUT	5V PULSE	12V / 24V PULSE
V _H	≥2.25V	≥5.25V
V _L	≤1.75V	≤4.75V

• **Two-wire Current Pulse**

Input resistance: receiving resistor 220Ω

Maximum current: ±50mA

Hi/Lo level: ≤5mA for Lo, ≥15mA for Hi

■ **OUTPUTS (two)**

• **Open Collector:** 50V DC @50mA (resistive load)

Maximum frequency: 100 kHz with load resistance ≤1kΩ

Saturation voltage: 0.5V DC

• **Voltage Pulse:** rating (5 or 12V) ±10%

Maximum frequency: 100 kHz

Load resistance: 1.5kΩ min. for 5V, 3kΩ min. for 12V

• **Relay Contact:** 120V AC or 30V DC @200mA (resistive load)

Maximum frequency: 0.5 Hz

Relay life: 2 × 10⁷ cycles (mechanical)
7 × 10⁶ cycles (electrical)

■ **OUTPUT PULSE WIDTH**

• **Equal to the Input:** no pulse width conversion (difference between input and output within ±10 μsec.)

• **One-shot Output:** constant pulse width

$$\text{Output Frequency (Hz)} = \frac{500}{\text{Output Pulse Width (msec.)}}$$

Adjustable pulse width

Pulse width max. 30 msec. (code 2): 1 – 30 msec. adjustable (standard 5 msec. ±20%)

Pulse width min. 30 msec. (code 3): 30 msec. – 1 sec. adjustable (standard 50 msec. ±20%)

Specifications subject to change without notice.

INSTALLATION

Power input

AC: operational voltage range: rating ±10%, 50/60 ±2 Hz, approx. 2.5VA

DC: operational voltage range: rating ±10% (ripple 10% p-p max.) approx. 2W (80mA at 24V)

Operating temperature: -5 to +60°C (23 to 140°F)

Operating humidity: 30 to 90% RH (non-condensing)

Mounting: surface or DIN rail

Dimensions: W50×H80×D136 mm (1.97"×3.15"×5.35")
See General Spec. Sheet Figure A.

Weight: 400 g (0.88 lbs)

Terminal assignment: See General Spec. Sheet Figure B-1.

PERFORMANCE

Insulation resistance: ≥100MΩ with 500V DC

Dielectric strength: 2000V AC @1 minute (input to output to power to ground)

1000V AC @1 minute (output ch.1 to ch.2)

FRONT PANEL CONFIGURATION

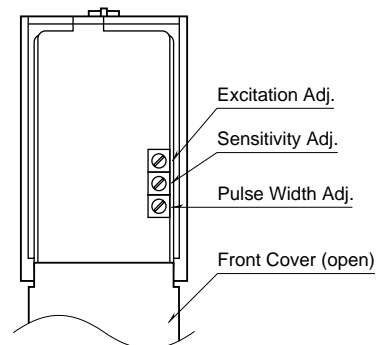











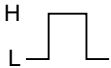

• **Excitation adjustment:** 5 – 12V

• **Sensitivity adjustment:** threshold level for voltage input; 2 – 10V

• **Pulse width adjustment:** for one-shot output; 1 – 30 msec. or 30 msec. – 1 sec.

OUTPUT LOGIC

■When an Open Collector is not Mixed with the Another Output Type:





INPUT TYPE	PULSE LOGIC	INPUT	VOLTAGE PULSE OUTPUT	OPEN COLLECTOR or RELAY CONTACT
Voltage Pulse Input 2-wire Current Pulse Input [ON current (H)] [OFF current (L)]	Non Inverted	H  L	H  L	OFF  ON
	Inverted	H  L	H  L	OFF  ON
Dry Contact Input	Non Inverted	OFF  ON	H  L	OFF  ON
	Inverted	OFF  ON	H  L	OFF  ON

The pulse width in one-shot means the bold lined section of a pulse waveform.



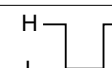
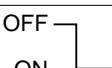

■When an Open Collector is Mixed with Another Output Type:

When combinations "a voltage pulse and an open collector" or "a relay contact and an open collector" are chosen, be aware that the logic of the output 2 is inverted.



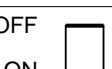
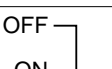

[example 1] Input : voltage pulse
Output 1 : voltage pulse
Output 2 : open collector

PULSE LOGIC	INPUT (voltage pulse)	OUTPUT 1 (voltage pulse)	OUTPUT 2 (open collector)
Non Inverted	H  L	H  L	OFF  ON
Inverted	H  L	H  L	OFF  ON

[example 2] Input : voltage pulse
Output 1 : relay contact
Output 2 : open collector

PULSE LOGIC	INPUT (voltage pulse)	OUTPUT 1 (relay contact)	OUTPUT 2 (open collector)
Non Inverted	H  L	OFF  ON	OFF  ON
Inverted	H  L	OFF  ON	OFF  ON

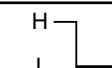
[example 3] Input : open collector
Output 1 : open collector
Output 2 : voltage pulse

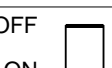
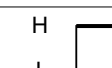
PULSE LOGIC	INPUT (open collector)	OUTPUT 1 (open collector)	OUTPUT 2 (voltage pulse)
Non Inverted	OFF  ON	OFF  ON	H  L
Inverted	OFF  ON	OFF  ON	H  L

SCHEMATIC CIRCUITRY & CONNECTION DIAGRAM

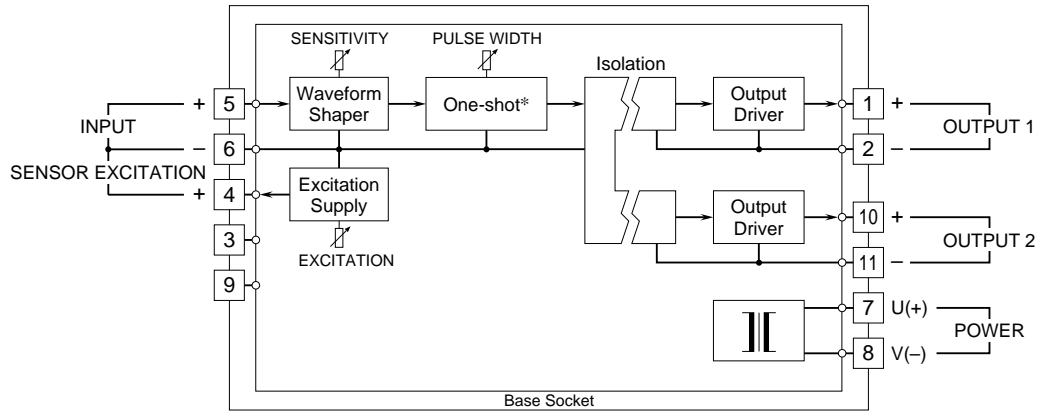

*Disregard one-shot circuit for output pulse width code "1"

Input Connection Examples

■ **Dry Contact**

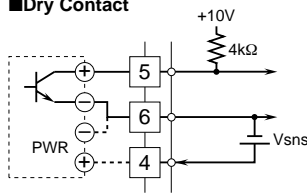

■ **Voltage Pulse**

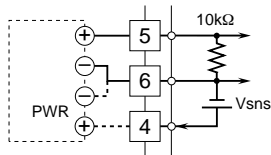

■ **2-Wire Current Pulse**
• **Built-in Excitation**

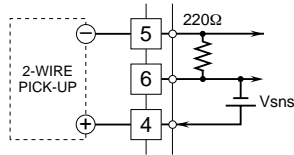

• **External DC Supply**

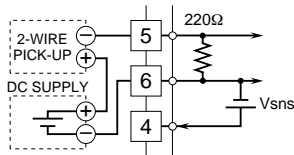

Output Connection Examples

■ **Open Collector**

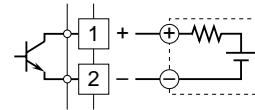

■ **Voltage Pulse**

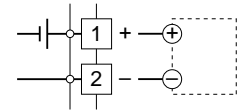

■ **Relay Contact**
• **AC Powered**

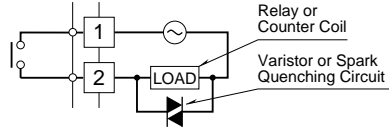

• **DC Powered**

