

Terminal Block Dual Output Signal Conditioners *W5-UNIT*

POTENTIOMETER TRANSMITTER

MODEL **W5MS**

MODEL & SUFFIX CODE SELECTION

W5MS-□□-□□

MODEL _____

INPUT POTENTIOMETER

Total resistance 100Ω – 10kΩ

OUTPUT 1 _____

Current

Voltage

A : 4 – 20mA DC	1 : 0 – 10mV DC
B : 2 – 10mA DC	2 : 0 – 100mV DC
C : 1 – 5mA DC	3 : 0 – 1V DC
D : 0 – 20mA DC	4 : 0 – 10V DC
E : 0 – 16mA DC	5 : 0 – 5V DC
F : 0 – 10mA DC	6 : 1 – 5V DC
G : 0 – 1mA DC	4W : -10 – +10V DC
Z : Specify current	5W : -5 – +5V DC
	0 : Specify voltage

OUTPUT 2 _____

Same range availability as Output 1

Y : None

POWER INPUT _____

AC Power

DC Power

M : 85 – 264V AC *1	R : 24V DC
	R2 : 11 – 27V DC *1
	P : 110V DC *1

*1 : CE not available

OPTIONS

/K : Fast response

ORDERING INFORMATION

Specify code number and variables. When only one (1) output is needed, the output must be assigned to Output 1 terminal.

- **Code number** (e.g. W5MS-A6-R/K)
- **Special output range** (For codes Z & 0)

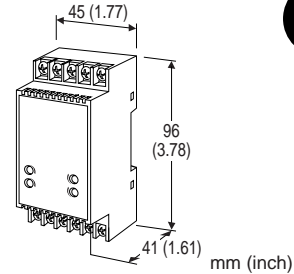

Functions & Features

- Provides two isolated DC output proportional to a potentiometer or slidewire position input
- Constant voltage excitation
- Two independent output ranges
- Universal power input
- Fast response type available
- High-density mounting
- CE marking for 24V DC power

GENERAL SPECIFICATIONS

Construction: Terminal block

Connection

Input: M3.5 screw terminals

Output & power: M3 screw terminals

Screw material: Nickel-plated steel

(torque 0.8 N·m)

Housing material: Flame-resistant resin (black)

Isolation: Input to output 1 to output 2 to power

Overrange output: Approx. -10 – +120% at 1 – 5V

Zero adjustment (front)

Output 1: 0 – 30% of the total resistance*

Output 2: ±2%

Span adjustment (front)

Output 1: 70 – 100% of the total resistance*

Output 2: ±2%

*Zero and span for the input potentiometer can be adjusted with the Zero and Span Adj. for the Output 1.

INPUT & OUTPUT

■**INPUT:** Potentiometer; 100Ω – 10kΩ
Minimum span: 70% of total resistance
Excitation: 0.5V DC

■**OUTPUTS (two)**

•**DC Current:** 0 – 20mA DC
Minimum span: 1mA
Zero suppression/elevation: Max. 1.5 times span
Load resistance: output drive 11V maximum

Output	Load Resistance
4 – 20mA	: 550 (Ω maximum)
2 – 10mA	: 1100
1 – 5mA	: 2200
0 – 20mA	: 550
0 – 16mA	: 685
0 – 10mA	: 1100
0 – 1mA	: 11k

•**DC Voltage:** -10 – +12V DC
Spans: Min. 5mV, max. 20V
Zero suppression/elevation: Max. 1.5 times span
Load resistance: Output drive 10mA maximum;

5mA for negative voltage output; at ≥0.5V

Output	Load Resistance
0 – 10mV	: 10k (Ω minimum)
0 – 100mV	: 100k
0 – 1V	: 100
0 – 10V	: 1000
0 – 5V	: 500
1 – 5V	: 500
-10 – +10V	: 2000
-5 – +5V	: 1000

INSTALLATION

Power input

AC: Operational voltage range 85 – 264V;
 47 – 66 Hz; approx. 4VA at 100V
 approx. 5VA at 200V
 approx. 6VA at 264V

DC: Operational voltage range for R: 24V
 ±10%, R2: 11 – 27V, or P: 85 – 150V;
 ripple 10% p-p max.; approx. 3W

Operating temperature: -5 to +55°C (23 to 131°F)
Operating humidity: 0 to 90% RH (non-condensing)

Mounting: DIN rail

Dimensions: W45×H96×D41 mm (1.77"×3.78"×1.61")
 See General Spec. Sheet Figure A-1.

Weight: 130 g (0.29 lbs)

Terminal assignment: See General Spec. Sheet Figure B-1.

PERFORMANCE in percentage of span

Accuracy: ±0.1%

Temp. coefficient: ±0.015%/°C (±0.008%/°F)

Response time: ≤0.5 seconds (0 – 90%)
 approx. 25 milliseconds with option /K

Line voltage effect: ±0.1% over voltage range

Insulation resistance: ≥100MΩ with 500V DC

Dielectric strength: 2000V AC @1 minute
 (input to output 1 or output 2 to power)
 1000V AC @1 minute (output 1 to output 2)

STANDARDS & APPROVALS

CE conformity: EMC Directive (89/336/EEC)
 EMI EN61000-6-4
 EMS EN61000-6-2

SCHEMATIC CIRCUITRY & CONNECTION DIAGRAM

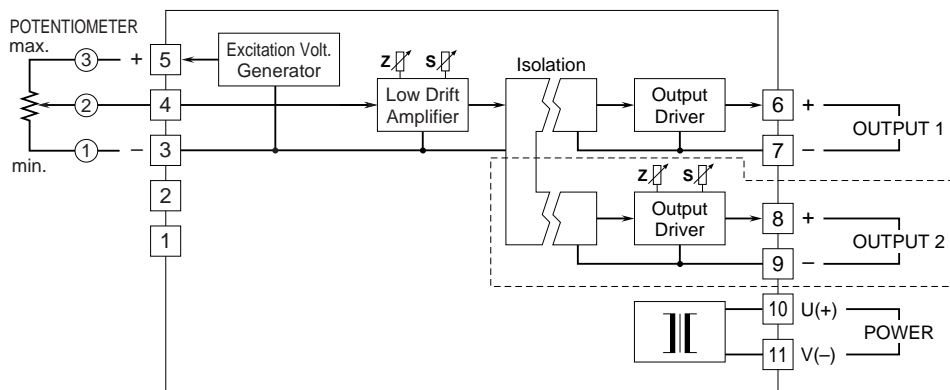

Remark 1: The section enclosed by broken line is only with 2nd output option.
 Remark 2: DO NOT connect to the terminals 1 – 2.