

Terminal Block Dual Output Signal Conditioners *W5-UNIT*

SIGNAL TRANSMITTER
(field-configurable)

MODEL **W5FV**

MODEL & SUFFIX CODE SELECTION

W5FV-□-□

MODEL _____

INPUT field-selectable

Current	Voltage
4 – 20mA DC	0 – 60mV DC
0 – 20mA DC	0 – 100mV DC
0 – 10mA DC	0 – 1V DC
	0 – 10V DC
	0 – 5V DC
	1 – 5V DC
	-10 – +10V DC
	-5 – +5V DC

OUTPUT 1 field-selectable

Current	Voltage
4 – 20mA DC	0 – 10V DC
0 – 20mA DC	0 – 5V DC
	1 – 5V DC
	-10 – +10V DC
	-5 – +5V DC

OUTPUT 2 specified when ordering

Y : None

Current	Voltage
A : 4 – 20mA DC	1 : 0 – 10mV DC
B : 2 – 10mA DC	2 : 0 – 100mV DC
C : 1 – 5mA DC	3 : 0 – 1V DC
D : 0 – 20mA DC	4 : 0 – 10V DC
E : 0 – 16mA DC	5 : 0 – 5V DC
F : 0 – 10mA DC	6 : 1 – 5V DC
G : 0 – 1mA DC	4W : -10 – +10V DC
Z : Specify current	5W : -5 – +5V DC
	0 : Specify voltage

POWER INPUT

AC Power	DC Power
M : 85 – 264V AC *1	R : 24V DC
	R2 : 11 – 27V DC *1
	P : 110V DC *1

*1: CE not available

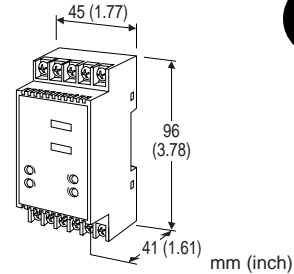

Functions & Features

- Converting a DC input
- Two independent output ranges
- DIP switch configurable input & output range
- Universal power input
- High-density mounting
- CE marking for 24V DC power

Typical Applications

- Isolation between control room and field instrumentation

ORDERING INFORMATION

Specify code number and variables. When only one (1) output is needed, the output must be assigned to Output 1 terminal. Orders will be shipped at default factory settings for Input (1 – 5V) and Output 1 (4 – 20mA).

- **Code number** (e.g. W5FV-6-R)
- **Special 2nd output range** (For codes Z & 0)

GENERAL SPECIFICATIONS

Construction: Terminal block

Connection

Input: M3.5 screw terminals

Output & power: M3 screw terminals

Screw material: Nickel-plated steel
(torque ≤0.8 N·m)

Housing material: Flame-resistant resin (black)

Isolation: Input to output 1 to output 2 to power

Overrange output: Approx. -10 – +120% at 1 – 5V

Front adjustments: ±2% for zero and span;
±1% with ±5V and ±10V input ranges

INPUT & OUTPUT**INPUT**

• **DC Current:** Input resistor incorporated

Input resistance: 250Ω

• **DC Voltage**

Input resistance: 1MΩ minimum

OUTPUT 1• **DC Current**

Load resistance: 550Ω maximum

• **DC Voltage**

Load resistance

Output	Load Resistance
0 – 10V	: 1000 (Ω minimum)
0 – 5V	: 500
1 – 5V	: 500
-10 – +10V	: 8000
-5 – +5V	: 4000

OUTPUT 2

• **DC Current:** 0 – 20mA DC

Minimum span: 1mA

Zero suppression/elevation: Max. 1.5 times span

Load resistance: output drive 11V maximum

Output	Load Resistance
4 – 20mA	: 550 (Ω maximum)
2 – 10mA	: 1100
1 – 5mA	: 2200
0 – 20mA	: 550
0 – 16mA	: 685
0 – 10mA	: 1100
0 – 1mA	: 11k

• **DC Voltage:** -10 – +12V DC

Spans: Min. 5mV, max. 20V

Zero suppression/elevation: Max. 1.5 times span

Load resistance: Output drive 10mA maximum;
5mA for negative voltage output; at ≥0.5V

Output	Load Resistance
0 – 10mV	: 10k (Ω minimum)
0 – 100mV	: 100k
0 – 1V	: 100
0 – 10V	: 1000
0 – 5V	: 500
1 – 5V	: 500
-10 – +10V	: 2000
-5 – +5V	: 1000

INSTALLATION**Power input**

AC: Operational voltage range 85 – 264V;
47 – 66 Hz; approx. 4VA at 100V
approx. 5VA at 200V
approx. 6VA at 264V

DC: Operational voltage range for R: 24V
±10%, R2: 11 – 27V, or P: 85 – 150V;
ripple 10% p-p max.; approx. 3W

Operating temperature: -5 to +55°C (23 to 131°F)

Operating humidity: 0 to 90% RH (non-condensing)

Mounting: DIN rail

Dimensions: W45×H96×D41 mm (1.77"×3.78"×1.61")
See General Spec. Sheet Figure A-1.

Weight: 130 g (0.29 lbs)

Terminal assignment: See General Spec. Sheet Figure B-1.

PERFORMANCE in percentage of span

Accuracy: ±0.1%

Temp. coefficient: ±0.015%/°C (±0.008%/°F)

Response time: ≤0.5 seconds (0 – 90%)

Line voltage effect: ±0.1% over voltage range

Insulation resistance: ≥100MΩ with 500V DC

Dielectric strength: 2000V AC @1 minute

(input to output 1 or output 2 to power)

1000V AC @1 minute (output 1 to output 2)

STANDARDS & APPROVALS

CE conformity: EMC Directive (89/336/EEC)

EMI EN61000-6-4

EMS EN61000-6-2

RANGE CONFIGURATION

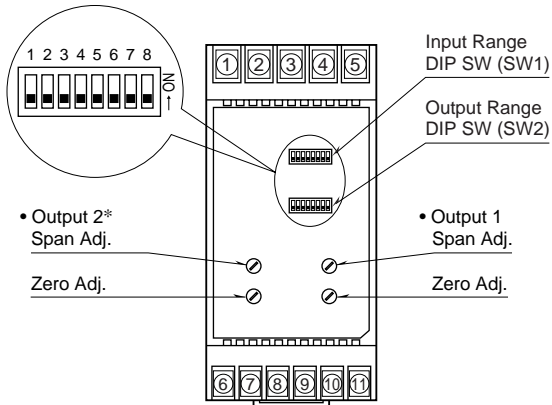

*Not provided for single output type.

INPUT RANGE DIP SW

Input exceeding the maximum value of each input range may destroy the transmitter. Be sure to confirm the setting range before applying input signals.

Input range setting accuracy: Approx. 1%*

INPUT RANGE	SW1							
	1	2	3	4	5	6	7	8
4 – 20mA				■			■	■
0 – 20mA	■					■		■
0 – 10mA	■				■			■
0 – 60mV	■							
0 – 100mV	■		■					
0 – 1V	■			■				
0 – 10V	■				■			■
0 – 5V	■					■		
1 – 5V				■				■
-10 – +10V		■				■	■	
-5 – +5V		■			■		■	

■ = ON, Blank = OFF

OUTPUT RANGE DIP SW

Only Output 1 is field-configurable. Specify Output 2 range when ordering.

Output range setting accuracy: Approx. 1%*

OUTPUT RANGE	SW2							
	1	2	3	4	5	6	7	8
4 – 20mA	■	■		■	■		■	
0 – 20mA		■		■	■		■	
0 – 10V			■	■		■		■
0 – 5V		■		■		■		■
1 – 5V	■	■		■		■		■
-10 – +10V						■		■
-5 – +5V			■			■		■

■ = ON, Blank = OFF

*≤2% when both input and output ranges are modified.

SCHEMATIC CIRCUITRY & CONNECTION DIAGRAM

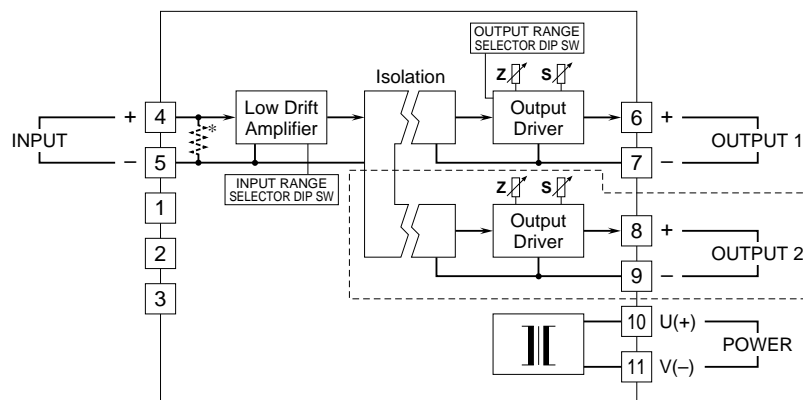

*Input shunt resistor attached for current input.

Remark 1: The section enclosed by broken line is only with 2nd output option.

Remark 2: DO NOT connect to the terminals 1 – 2 – 3.