

RELATED PRODUCTS

- JX configurator connection kit (model: JXCON)

GENERAL SPECIFICATIONS

Construction: Plug-in

Connection: M3 screw terminals (torque 0.8 N·m)

Housing material: Flame-resistant resin (black)

Isolation: input to output to power

Overrange output: approx. -15 – +115%

(Negative current output is not provided.)

Manual zero/span adjustments: See Front View.

Programming: PC programmable features include:

- T/C and RTD type and temp. range
- Linearization table
- Input and output ranges
- Zero and span adjustments
- Simulated output

Burnout protection (T/C, RTD and Pot.): Upscale standard; downscale or no burnout options are PC programmable

Linearization (DC, T/C and RTD)

DC: 100 points max. within the range of -15 – +115% input or output; specified in % of of full-scale (No table setting is done at shipping. [gain = 1])

T/C, RTD: Standard tables stored in memory

Cold Junction Compensation (T/C): CJC sensor (included) to be attached to the input terminals

Status indicator LED: Flashing patterns indicate operation status of the transmitter.

Configurator connection: 2.5 dia. miniature jack; RS-232C level

INPUT

■DC mV, V & mA

•DC Current

Input range: 0 – 50mA DC; shunt resistor (included) to be attached to the input terminals (100Ω, 0.5W)

Operational range: 0 – 70mA DC (100Ω, 0.5W)

Minimum span: 2mA

Offset: Lower range can be any specific value within the input range provided that the minimum span is maintained.

•DC Voltage

Input range: -10 – +10V DC

Operational range: -11.5 – +11.5V DC

Minimum span: 10mV for S1; 100mV for S2

Offset: Lower range can be any specific value within the input range provided that the minimum span is maintained.

■THERMOCOUPLE

Input resistance: 1MΩ minimum

Burnout sensing: 45nA ±10%

Offset: Lower range can be any specific value within the input range provided that the minimum span is maintained.

Temperature range

T/C	USABLE RANGE	
	°C	°F
(PR)	0 to 1760	32 to 3200
K (CA)*	-270 to +1370	-454 to +2498
E (CRC)*	-270 to +1000	-454 to +1832
J (IC)	-210 to +1200	-346 to +2192
T (CC)*	-270 to +400	-454 to +752
B (RH)*	0 to 1820	32 to 3308
R*	-50 to +1760	-58 to +3200
S*	-50 to +1760	-58 to +3200
C (WRe 5-26)	0 to 2315	32 to 4199
N*	-270 to +1300	-454 to +2372
U	-200 to +400	-328 to +752
L	-200 to +900	-328 to +1652
P (Platinel II)	0 to 1395	32 to 2543

*The transmitter may not satisfy specified accuracy for temperature ranges near the lower limits of the usable range. For more details, consult M-System.

■RTD (2- or 3-wire)

Maximum leadwire resistance: 200Ω per wire (3-wire)

Sensing current: ≤1.0mA

Temperature range

RTD	USABLE RANGE	
	°C	°F
JPt 100 (JIS '89)	-200 to +500	-328 to +932
Pt 100 (JIS '89)	-200 to +850	-328 to +1562
Pt 100 (JIS '97/DIN/IEC)	-200 to +850	-328 to +1562
Pt 50Ω (JIS '81)	-200 to +649	-328 to +1200
Ni 508.4Ω	-50 to +200	-58 to +392
Pt 1000	-200 to +200	-328 to +392
Ni 100	-50 to +200	-58 to +392
Cu 10	-50 to +200	-58 to +392

■POTENTIOMETER: 100Ω – 10kΩ

Minimum span

0 – 100Ω	: 2.5Ω
0 – 300Ω	: 3.0Ω
0 – 1000Ω	: 10Ω
0 – 10kΩ	: 10Ω

Excitation: ≤0.5V DC at 1kΩ

OUTPUT

■ **DC CURRENT:** 0 – 20mA DC

Operational range: 0 – 24mA DC

Minimum span: 1mA

Offset: Lower range can be any specific value within the input range provided that the minimum span is maintained.

Load resistance: Output drive 15V maximum (e.g. 4 – 20mA: 750Ω [15V/20mA])

■ **DC VOLTAGE:** -2.5 – +2.5V DC for V1;
-10 – +10V DC for V2

Operational range: -3 – +3V DC for V1;
-11.5 – +11.5V DC for V2

Minimum span: 250mV for V1; 1V for V2

Offset: Lower range can be any specific value within the input range provided that the minimum span is maintained.

Load resistance: Output drive 1mA maximum (e.g. 1 – 5V: 5000Ω [5V/1mA])

INSTALLATION

Power input

AC: Operational voltage range 85 – 264V;
(90 – 264V for UL);
47 – 66 Hz, approx. 6VA

DC: Operational voltage range for R: 24V ±10%
or P: 85 – 150V (110V ±10% for UL);
approx. 3W (ripple 10% p-p max.)

Operating temperature: -30 to +60°C (-22 to +140°F)

Operating humidity: 30 to 90% RH (non-condensing)

Mounting: Surface or DIN rail

Dimensions: W23×H81×D124 mm (0.91"×3.19"×4.88")
See General Spec. Sheet Figure A-2.

Weight: 120 g (0.26 lbs)

PERFORMANCE

Accuracy: Input accuracy + output accuracy

Input accuracy:** (% of input range)

(DC)	-1 – +1V	: ≤ ±0.02 (%)
	-10 – +10V	: ≤ ±0.02
	0 – 50mA	: ≤ ±0.02***
(T/C)	(PR)	: ≤ ±0.08
	K (CA)	: ≤ ±0.02
	E (CRC)	: ≤ ±0.02
	J (IC)	: ≤ ±0.04
	T (CC)	: ≤ ±0.06
	B (RH)	: ≤ ±0.12
	R	: ≤ ±0.08
	S	: ≤ ±0.08
	C (WRe 5-26)	: ≤ ±0.04
	N	: ≤ ±0.04
	U	: ≤ ±0.04
	L	: ≤ ±0.04
	P (Platinel II)	: ≤ ±0.04

(RTD)	JPt 100 (JIS '89)	: ≤ ±0.04
	Pt 100 (JIS '89)	: ≤ ±0.03
	Pt 100 (JIS '97/DIN/IEC751)	: ≤ ±0.03
	Pt 50Ω (JIS '81)	: ≤ ±0.04
	Ni 508.4Ω	: ≤ ±0.05
	Pt 1000	: ≤ ±0.08
	Ni 100	: ≤ ±0.14
	Cu 10	: ≤ ±0.6
(Pot.)	0 – 100Ω	: ≤ ±0.08
	0 – 300Ω	: ≤ ±0.04
	0 – 1000Ω	: ≤ ±0.04
	0 – 10kΩ	: ≤ ±0.04

Output accuracy:** ≤ ±0.02% of output range

**Inversely proportional to span.

[e.g.] Input accuracy at 1 – 5V:

$$\frac{\text{Code S2 Range (20V)}}{\text{Input Span (4V)}} \times \text{Input Accuracy } (\pm 0.02\%) = \pm 0.1\%$$

***Not including input resistor error.

Cold junction compensation error: ±0.4°C or ±0.7°F
maximum (at 20°C ±10°C or 68°F ±18°F)

Temp. coefficient

(at -5 to +55°C [23 to 131°F] of I/O range)

Input: ±0.016%/°C (±0.009%/°F) with current
±0.004%/°C (±0.002%/°F) with voltage
±0.004%/°C (±0.002%/°F) with T/C
±0.004%/°C (±0.002%/°F) with RTD
±0.004%/°C (±0.002%/°F) with Pot.

Output: ±0.013%/°C (±0.007%/°F)

Response time: ≤0.5 seconds (0 – 90%) with current
≤0.5 seconds (0 – 90%) with voltage
≤1.5 seconds (0 – 90%) with T/C
≤0.9 seconds (0 – 90%) with RTD
≤0.9 seconds (0 – 90%) with Pot.

Burnout response: ≤10 seconds

Line voltage effect: ±0.1% over voltage range

Insulation resistance: ≥100MΩ with 500V DC

Dielectric strength: 2000V AC @1 minute

(input to output to power to ground)

STANDARDS & APPROVALS

CE conformity: EMC Directive (89/336/EEC)

EMI EN61000-6-4

EMS EN61000-6-2

Low Voltage Directive (73/23/EEC)

Installation category II

Pollution degree 2

Max. operating voltage 300V

Input or output to power – Reinforced insulation

Input to output – Basic insulation

Approval: UL/C-UL nonincendive Class I, Division 2, Groups A, B, C, and D hazardous locations (UL 1604, CAN/CSA-C22.2 No.213); UL/C-UL general safety requirements (UL 3111-1, CAN/CSA-C22.2 No.1010-1)

FRONT & SIDE VIEWS

■ **FRONT VIEW (with cover open)**

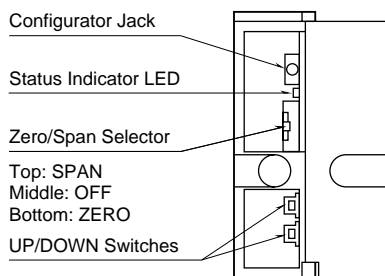

■ **RIGHT SIDE VIEW**

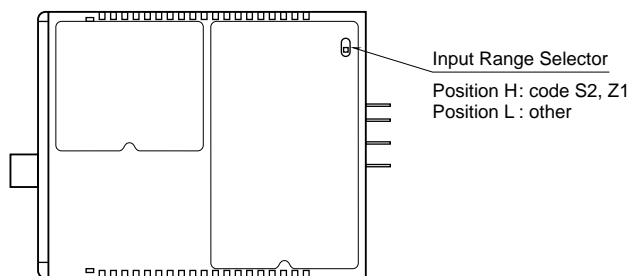

The front cover cannot be opened to 180 deg. when flush with neighboring units.

Manual zero/span adjustments: $\pm 5\%$ (set to 0% and 100% respectively at factory)

Zero/Span selector

- ZERO:** UP/DOWN switches enabled to access zero adjustment.
- OFF:** UP/DOWN switches disabled.
- SPAN:** UP/DOWN switches enabled to access span adjustment.

UP/DOWN switches

- UP:** Pressing UP increases adjusted values.
 - DOWN:** Pressing DOWN decreases adjusted values.
- (Press both switches at once to rest zero/span adjustments.)

SCHEMATIC CIRCUITRY & CONNECTION DIAGRAM

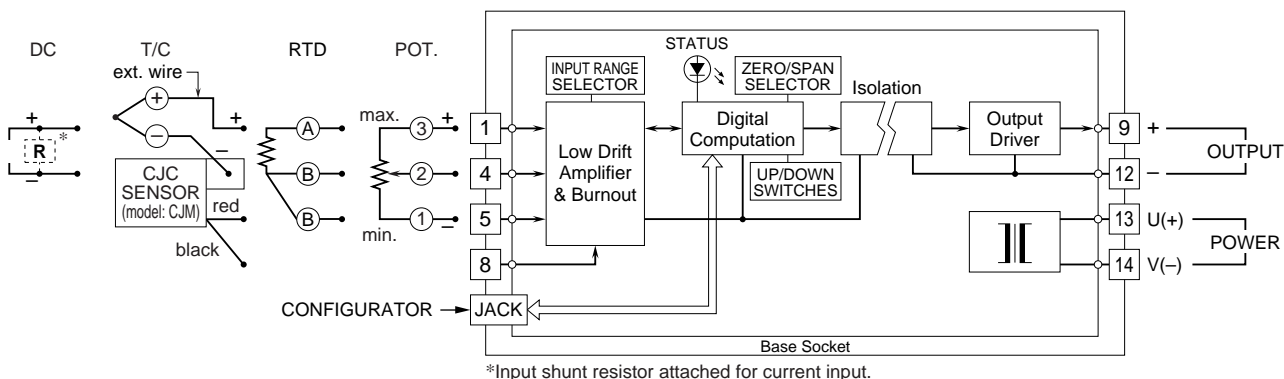

TERMINAL ASSIGNMENTS mm (inch)

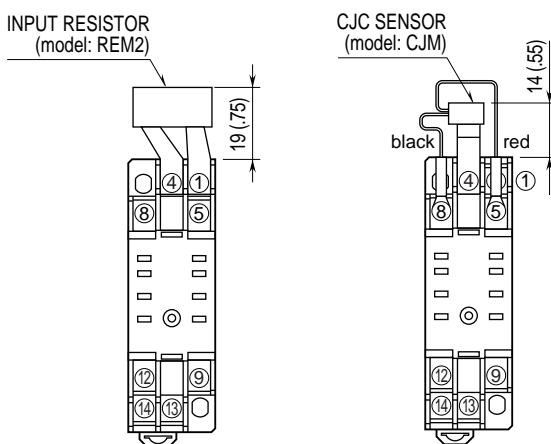

Use the input resistor (model: REM2) for a DC current input, and the CJC sensor (model: CJM) for a thermocouple input, both included in the package.

Specifications subject to change without notice.