

**Super-mini Signal Conditioners *Mini-M Series***

**PEAK HOLD**

MODEL **M2PHS**

**MODEL & SUFFIX CODE SELECTION**

M2PHS□□□□

MODEL

HOLD FUNCTION

H : Peak hold

L : Valley hold

W : Peak-to-peak hold \*1

\*1 : Select 'N' or 'CE' for 'Standards & Approvals' code.

INPUT

Current

Voltage

A : 4 – 20mA DC

1 : 0 – 10mV DC

A1: 4 – 20mA DC \*2

15: 0 – 50mV DC

B : 2 – 10mA DC

16: 0 – 60mV DC

C : 1 – 5mA DC

2 : 0 – 100mV DC

D : 0 – 20mA DC

3 : 0 – 1V DC

E : 0 – 16mA DC

4 : 0 – 10V DC

F : 0 – 10mA DC

5 : 0 – 5V DC

G : 0 – 1mA DC

6 : 1 – 5V DC

H : 10 – 50mA DC

4W: -10 – +10V DC

J : 0 – 10µA DC

5W: -5 – +5V DC

K : 0 – 100µA DC

0 : Specify voltage

GW: -1 – +1mA DC

FW: -10 – +10mA DC

Z : Specify current

\*2 : 50Ω input resistance for Code A1

OUTPUT

Current

Voltage

A : 4 – 20mA DC

1 : 0 – 10mV DC

B : 2 – 10mA DC

2 : 0 – 100mV DC

C : 1 – 5mA DC

3 : 0 – 1V DC

D : 0 – 20mA DC

4 : 0 – 10V DC

E : 0 – 16mA DC

5 : 0 – 5V DC

F : 0 – 10mA DC

6 : 1 – 5V DC

G : 0 – 1mA DC

4W: -10 – +10V DC

Z : Specify current

5W: -5 – +5V DC

0 : Specify voltage

POWER INPUT

AC Power

DC Power

M2: 100 – 240V AC

R : 24V DC

R2: 11 – 27V DC \*3

P : 110V DC

\*3 : Select 'N' for 'Standards & Approvals' code.

**STANDARDS & APPROVALS**

/N : Without CE or UL

/CE: CE marking

/UL: UL approval (CE marking)

**ORDERING INFORMATION**

Specify code number and variables.

• **Code number** (e.g. M2PHSH-6A-M2/CE)

• **Special input and output ranges** (For codes Z & 0)

**ISOLATION**

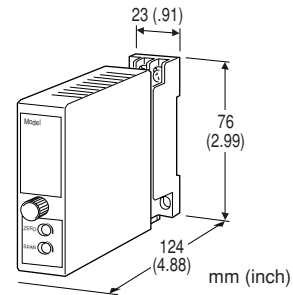

**Functions & Features**

- Track mode: the output follows proportionally to the input
- Peak-hold mode: responds only to an increasing signal, holding the maximum value until a higher signal or a command to reset is received
- Valley hold and peak-to-peak mode selectable
- Universal power input
- CE marking
- UL approval

**Typical Applications**

- Monitoring peak power consumption
- Monitoring the highest or lowest temperature

**GENERAL SPECIFICATIONS**

**Construction:** plug-in

**Connection:** M3 screw terminals (torque 0.8 N·m)

**Housing material:** flame-resistant resin (black)

**Isolation:** input to output to power

**Overrange input:** approx. -10 – +120% at 1 – 5V

**Overrange output:** approx. -10 – +120% at 1 – 5V

**Zero/span adjustments:** ±5% (front)

**Hold control:** Holds when opening the terminals 5 – 8; Tracks when closing them

**INPUT & OUTPUT**

**INPUT**

• **DC Current:** shunt resistor attached to input terminals (0.5W)

**Input resistance:** For resistance values other than listed below, specify when ordering.

4 – 20mA : 250 (Ω)  
(50Ω for Code A1)

2 – 10mA : 500

1 – 5mA : 1000

0 – 20mA : 50

0 – 16mA : 62.5

0 – 10mA : 100

0 – 1mA : 1000

10 – 50mA : 100

0 – 10µA : 1000

0 – 100µA : 1000

-1 – +1mA : 1000

-10 – +10mA : 100

•DC Voltage: -300 – +300V DC

Minimum span: 3mV

Zero suppression/elevation: max. 1.5 times span

Input resistance

(Span) 3 – 10mV	: 10k ( $\Omega$ minimum)
10 – 100mV	: 10k
0.1 – 1V	: 100k
$\geq 1V$	: 1M

#### ■HOLD CONTROL

Contact rating: 5V @1mA

Detection levels:  $\leq 1.25k\Omega/1V$  at Track,  
 $\geq 20k\Omega/4V$  at Hold

#### ■OUTPUT

•DC Current: 0 – 20mA DC

Minimum span: 1mA

Zero suppression/elevation: max. 1.5 times span

Load resistance: output drive 15V maximum

4 – 20mA	: 750 ( $\Omega$ maximum)
2 – 10mA	: 1500
1 – 5mA	: 3000
0 – 20mA	: 750
0 – 16mA	: 900
0 – 10mA	: 1500
0 – 1mA	: 15k

•DC Voltage: -10 – +12V DC

Minimum span: 5mV

Zero suppression/elevation: max. 1.5 times span

Load resistance: output drive 1mA maximum at  $\geq 0.5V$

0 – 10mV	: 10k ( $\Omega$ minimum)
0 – 100mV	: 100k
0 – 1V	: 1000
0 – 10V	: 10k
0 – 5V	: 5000
1 – 5V	: 5000
-10 – +10V	: 10k
-5 – +5V	: 5000

## INSTALLATION

### Power input

**AC:** operational voltage range 85 – 264V  
(90 – 264V for UL);  
47 – 66 Hz; approx. 3VA at 100V  
approx. 4VA at 200V  
approx. 5VA at 264V

**DC:** operational voltage range for R: 24V  $\pm 10\%$   
or P: 85 – 150V (110V  $\pm 10\%$  for UL);  
ripple 10% p-p max.; approx. 3W

**Operating temperature:** -5 to +55°C (23 to 131°F)

**Operating humidity:** 30 to 90% RH (non-condensing)

**Mounting:** surface or DIN rail

**Dimensions:** W23×H76×D124 mm (0.91"×2.99"×4.88")

See General Spec. Sheet Figure A-1.

**Weight:** 150 g (0.33 lbs)

**Terminal assignment:** See General Spec. Sheet Figure B-2.

## PERFORMANCE in percentage of span

**Accuracy:**  $\pm 0.2\%$

**Temp. coefficient:**  $\pm 0.015\%/^{\circ}C$  ( $\pm 0.008\%/^{\circ}F$ )

**Response time:**  $\leq 0.5$  seconds (0 – 90%)

**Line voltage effect:**  $\pm 0.1\%$  over voltage range

**Insulation resistance:**  $\geq 100M\Omega$  with 500V DC

**Dielectric strength:** 2000V AC @1 minute

(input to output to power to ground)

## STANDARDS & APPROVALS

**CE conformity:** EMC Directive (89/336/EEC)

EMI EN61000-6-4

EMS EN61000-6-2

Low Voltage Directive (73/23/EEC)

EN61010-1

Installation category II

Pollution degree 2

Max. operating voltage 300V

Input or output to power – Reinforced insulation

Input to output – Basic insulation

**Approval:** UL/C-UL nonincendive

Class I, Division 2, Groups A, B, C, and D  
(UL 1604, CAN/CSA-C22.2 No.213)

UL/C-UL general safety requirements

(UL 3111-1, CAN/CSA-C22.2 No.1010-1)

## SCHEMATIC CIRCUITRY & CONNECTION DIAGRAM

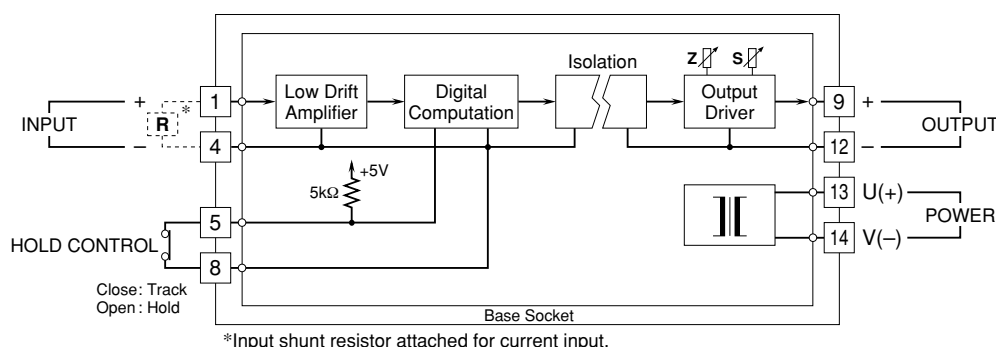

Specifications subject to change without notice.