

Space-saving Two-wire Signal Conditioners B3-UNIT

SIGNAL TRANSMITTER (single- and dual-channel output loop powered isolator)	MODEL B3VS/2 B3VS/1
--	--------------------------------------

MODEL & SUFFIX CODE SELECTION

B3VS/2-□□□
B3VS/1-□ □

MODEL _____

B3VS/2 : Dual channel
B3VS/1 : Single channel

CH. 1 INPUT _____

Current	Voltage
A : 4 – 20mA DC	3 : 0 – 1V DC
B : 2 – 10mA DC	4 : 0 – 10V DC
C : 1 – 5mA DC	5 : 0 – 5V DC
D : 0 – 20mA DC	6 : 1 – 5V DC
F : 0 – 10mA DC	4W : -10 – +10V DC
H : 10 – 50mA DC	5W : -5 – +5V DC
Z : Specify current	0 : Specify voltage

CH. 2 INPUT _____

Same range availability as for Ch. 1.
Blank for single channel type.

OUTPUT
4 – 20mA DC

SUPPLY VOLTAGE
12 – 45V DC

OPTIONS _____

/UL : UL approval

ORDERING INFORMATION

Specify code number and variables.

- **Code number** (e.g. B3VS/2-A6)
- **Special input range** (For codes Z and 0)

GENERAL SPECIFICATIONS

Connection: Removable terminal block
Housing material: Flame-resistant resin (grey)
Isolation: Input to output; ch.1 I/O to ch.2 I/O
Front adjustments: ±5% for zero and span



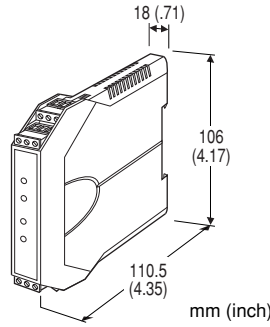



Functions & Features

- Converting a DC input into an isolated standard DC signal
- Single and dual channel types available
- Monitor terminals
- High-density mounting
- CE marking
- UL approval

INPUT & OUTPUT

INPUT

- **DC Current:** Input resistor incorporated
- Input resistance:** For resistance values other than listed below, specify when ordering.
(Input Resistance ≤ 0.25W / [Input Current]²)

Input Span	Input Resistance
4 – 20mA	: 250 (Ω)
2 – 10mA	: 499
1 – 5mA	: 1000
0 – 20mA	: 250
0 – 10mA	: 499
10 – 50mA	: 100

- **DC Voltage:** -100 – +100V DC
(Max. voltage across the input terminals: 70V for CE conformity; 60V for UL approval)

Spans: Min. 1V, max. 100V

Zero suppression/elevation: Max. 1.5 times span

Input resistance

Input Span	Input Resistance
1 – 2V	: 1M (Ω minimum) (≥80kΩ with no supply voltage)
≥2V	: 1M

OUTPUT: 4 – 20mA DC

Load resistance vs. supply voltage:

$$\text{Load Resistance } (\Omega) = \frac{\text{Supply Voltage (V)} - 12 \text{ (V)}}{0.02 \text{ (A)}}$$

(including leadwire resistance)

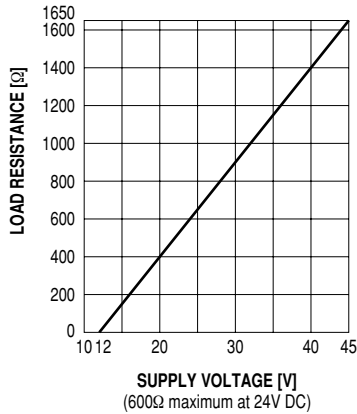

INSTALLATION

Supply voltage: 12 – 45V DC

Operating temperature: -40 to +85°C (-40 to +185°F)
Max. 55°C (131°F) for UL approval

Operating humidity: 0 to 95% RH (non-condensing)

Mounting: DIN rail

Dimensions: W18×H106×D110.5 mm
(0.71"×4.17"×4.35")

See General Spec. Sheet Figure A-1.

Weight: 110 g (0.24 lbs)

Terminal assignment: See General Spec. Sheet Figure B-3.

PERFORMANCE in percentage of span

Accuracy: ±0.1%

Temp. coefficient: ±0.02%/°C (±0.01%/°F)

Response time: ≤0.1 seconds (0 – 90%)

Insulation resistance: ≥100MΩ with 500V DC

Dielectric strength: 2000V AC @1 minute (input to output to ground, ch.1 I/O to ch.2 I/O)

STANDARDS & APPROVALS

CE conformity: EMC Directive (89/336/EEC)

EMI EN61000-6-4

EMS EN61000-6-2

Approval: UL/C-UL general safety requirements

(UL 61010-1, CAN/CSA-C22.2 No.1010-1)

SCHEMATIC CIRCUITRY & CONNECTION DIAGRAM

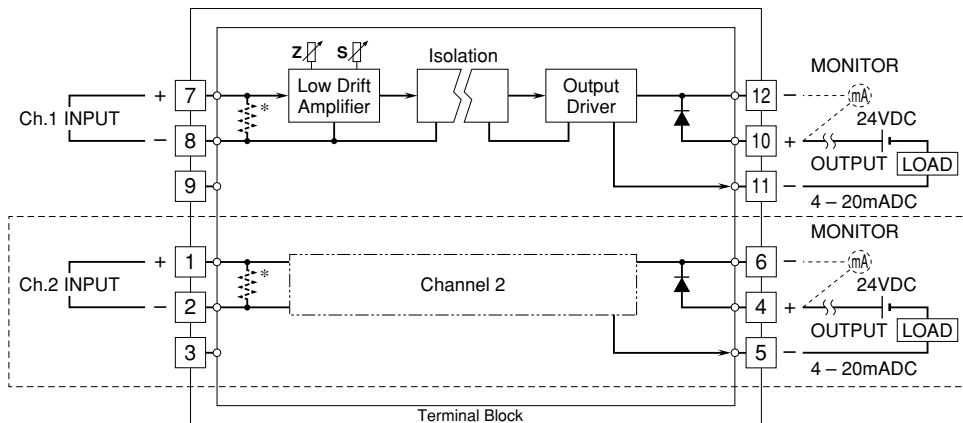

*Input shunt resistor incorporated for current input.
The section enclosed by broken line is with 2-ch. option.