

Power Transducer Series *LT-UNIT*

WATT TRANSDUCER

MODEL LTWT

MODEL & SUFFIX CODE SELECTION

LTWT-□□□□□□□□

MODEL _____

CONFIGURATION _____

- 1 : 3-phase / 3-wire
- 2 : Single-phase / 2-wire
- 3 : Single-phase / 3-wire
- 4 : 3-phase / 4-wire

VT INPUT (unbalanced load) _____

- 1 : 100, 110, 115, 120V AC*1
- 2 : 190, 200, 210, 220, 230, 240V AC*1
- 4 : 380, 400, 415, 430, 440, 480V AC*1
- A : 100V / 200V AC (single-phase/3-wire only)

For 3-phase/4-wire, phase voltages (e.g. 110V/ $\sqrt{3}$) are used.

*1: Not selectable for single-phase/3-wire.

CT INPUT (unbalanced load) _____

- 1 : 1A AC
- 2 : 2A AC
- 5 : 5A AC

DC OUTPUT _____

Current	Voltage
A : 4 – 20mA DC	1 : 0 – 10mV DC
D : 0 – 20mA DC	2 : 0 – 100mV DC
F : 0 – 10mA DC	3 : 0 – 1V DC
G : 0 – 1mA DC	4 : 0 – 10V DC
J : 0 – 5mA DC	5 : 0 – 5V DC
FW : -10 – +10mA DC	6 : 1 – 5V DC
GW : -1 – +1mA DC	1W : -10 – +10mV DC
JW : -5 – +5mA DC	2W : -100 – +100mV DC
Z : Specify current	3W : -1 – +1V DC
	4W : -10 – +10V DC
	5W : -5 – +5V DC
	0 : Specify voltage

PULSE OUTPUT (open collector) _____

- 0 : None
- 1 : 2.777 Hz at 100% input
- 2 : Specify pulse unit (within 0.006 – 3.12 Hz)

AUXILIARY POWER SUPPLY _____

AC Power	DC Power
K3: 100 – 120V AC	R : 24V DC
L3: 200 – 240V AC	V : 48V DC
	P : 110V DC *2

*2: CE marking unavailable

OPTIONS _____

/T : Terminal cover

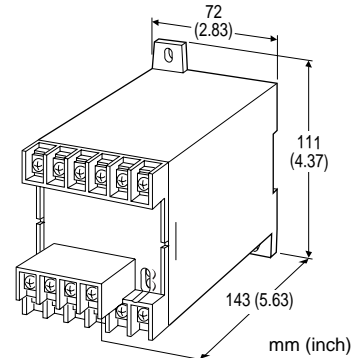

Functions & Features

- Providing a DC output signal and pulse totalizer signal in proportion to AC active power
- Convenient pulse unit output (Wh $\times 10^n$)
- Measuring bidirectional power flow
- DC output containing little ripple is ideal for computer input
- "Time division multiplication" method accepts distorted waveforms
- Isolation up to 2000V AC
- High-density mounting
- Conforms to IEC 60688

Typical Applications

- Centralized monitoring and control of power management system in a manufacturing facility or building
- SCR – Silicon Controlled Rectifier

How To Determine Wattage Range

$$\text{Calibration Range [W]} = \frac{\text{Measuring Wattage}}{(\text{VT Ratio}) \times (\text{CT Ratio})}$$

Check that the required calibration range is within the available range in the table. Specify this range when ordering.

[example]

3-phase / 3-wire, measuring wattage 750kW, VT 3300/110V, CT 250/5A

$$\frac{750 \times 10^3 \text{ [W]}}{(3300/110) \times (250/5)} = 0 - 500 \text{ [W]}$$

How To Determine Pulse Unit

[example]

3-phase / 3-wire, VT 3300/110V, CT 250/5A, calibration range 750W

$$\frac{10 \text{ [kWh/pulse]}}{(3300/110) \times (250/5)} = 6.666 \times 10^{-3} \text{ [kWh/pulse]} = 6.666 \text{ [Wh/pulse]}$$

Check that the required pulse unit is within the available frequency range, 0.006 – 3.12 Hz.

$$\frac{\text{Input Range [W]}}{\text{Calculated Pulse} \times 3600 \text{ [s]}} = \frac{750}{6.666 \times 3600} = 0.03125 \text{ [Hz]}$$

ORDERING INFORMATION

Specify code number and variables. Use Ordering Information Sheet (No. ESU-3355).

• **Code number** (e.g. LTWT-115A2-R)

GENERAL SPECIFICATIONS

Construction: stand-alone; terminal access at the front

Connection: M4 screw terminals
(chrome-plated steel; torque 1.2 N·m)

Housing material: flame-resistant resin (black)

Isolation: voltage input to current input to DC output to pulse output to power

Computation: time division multiplication

Overrange output: approx. -10 – +120% at 1 – 5V

Front adjustments (DC output): zero and span; ±5%

INPUT & OUTPUT

■ **INPUT**

Frequency: 50 or 60 Hz

• **Voltage Input**

Operational range: 0 – 120% of rating

Overload capacity: 200% of rating for 10 sec.,
120% continuous

• **Current Input**

Operational range: 0 – 120% of rating

Overload capacity: 4000% of rating for 1 sec., 2000%
for 4 sec., 120% continuous

■ **INPUT RANGE**

• **Single-phase / 2-wire**

VT / CT CODE	INPUT		BURDEN (VA)	
	STD.RANGE	USABLE RANGE	VT	CT
1 / 1	±100W	±50 – ±120W	0.2	0.1
1 / 2	±200W	±100 – ±240W		0.2
1 / 5	±500W	±250 – ±600W		0.5
2 / 1	±200W	±100 – ±240W	0.4	0.1
2 / 2	±400W	±200 – ±480W		0.4
2 / 5	±1000W	±500 – ±1200W		0.5
4 / 1	±400W	±200 – ±480W	0.5	0.1
4 / 2	±800W	±400 – ±960W		0.5
4 / 5	±2000W	±1000 – ±2400W		0.5

• **Single-phase / 3-wire**

VT / CT CODE	INPUT		BURDEN (VA)	
	STD.RANGE	USABLE RANGE	VT	CT
A / 1	±200W	±100 – ±240W	0.2 /phase	0.1/ph
A / 2	±400W	±200 – ±480W		0.2/ph
A / 5	±1000W	±500 – ±1200W		0.5/ph

• **3-phase / 3-wire**

VT / CT CODE	INPUT		USABLE RANGE	BURDEN (VA)	
	STD.RANGE			VT	CT
1 / 1	±200W	±100 – ±240W	0.2 /phase	0.1/ph	
1 / 2	±400W	±200 – ±480W		0.2/ph	
1 / 5	±1000W	±500 – ±1200W		0.5/ph	
2 / 1	±400W	±200 – ±480W	0.4 /phase	0.1/ph	
2 / 2	±800W	±400 – ±960W		0.2/ph	
2 / 5	±2000W	±1000 – ±2400W		0.5/ph	
4 / 1	±800W	±400 – ±960W	0.6 /phase	0.1/ph	
4 / 2	±1600W	±800 – ±1920W		0.2/ph	
4 / 5	±4000W	±2000 – ±4800W		0.5/ph	

• **3-phase / 4-wire**

VT / CT CODE	INPUT		USABLE RANGE	BURDEN (VA)	
	STD.RANGE			VT	CT
1 / 1	±200W	±100 – ±240W	0.1 /phase	0.1/ph	
1 / 2	±400W	±200 – ±480W		0.2/ph	
1 / 5	±1000W	±500 – ±1200W		0.5/ph	
2 / 1	±400W	±200 – ±480W	0.3 /phase	0.1/ph	
2 / 2	±800W	±400 – ±960W		0.2/ph	
2 / 5	±2000W	±1000 – ±2400W		0.5/ph	
4 / 1	±800W	±400 – ±960W	0.4 /phase	0.1/ph	
4 / 2	±1600W	±800 – ±1920W		0.2/ph	
4 / 5	±4000W	±2000 – ±4800W		0.5/ph	

■ **OUTPUT**

• **DC Current:** -10 – +20mA DC

Span: min. 1mA, max. 20mA

Zero suppression/elevation: max. 1.5 times span

Load resistance: output drive 10V maximum

Output	Load Resistance
4 – 20mA	: 500 (Ω maximum)
0 – 20mA	: 500
0 – 10mA	: 1000
0 – 1mA	: 10k
0 – 5mA	: 2000
-10 – +10mA	: 1000
-1 – +1mA	: 10k
-5 – +5mA	: 2000

• **DC Voltage:** -10 – +12V DC

Minimum span: 5mV

Zero suppression/elevation: max. 1.5 times span

Load resistance: output drive 1mA maximum at ≥0.5V

Output	Load Resistance
0 – 10mV	: 10k (Ω minimum)
0 – 100mV	: 100k
0 – 1V	: 1000
0 – 10V	: 10k
0 – 5V	: 5000
1 – 5V	: 5000
-10 – +10mV	: 10k
-100 – +100mV	: 100k
-1 – +1V	: 1000
-10 – +10V	: 10k
-5 – +5V	: 5000

■ **PULSE OUTPUT:** open collector; 0 Hz at 0W

(cutout at approx. 0.5 – 1.0%)

Rating: 35V DC @100mA

ON voltage: ≤1V at 100mA

ON duration: max. 0.5 sec., min. approx. 50 msec.

Frequency range: 0 – 2.777 Hz (0 – 100%) standard;
0 – 0.006 Hz through 3.12 Hz is possible.

• **2.777 Hz at 100% Input**

[example] 1000W calibration range

$$\frac{2.777 \text{ [Hz]} \times 3600 \text{ [s]}}{1 \text{ [kW]}} = 10000 \text{ [pulses/kWh]}$$

• **Specified Pulse Unit:** refers to how much electrical energy (kWh) consumption at the primary of the VT and CT corresponds to the single output pulse per hour from the transducer.

■ **OPERATION DIAGRAM (example)**

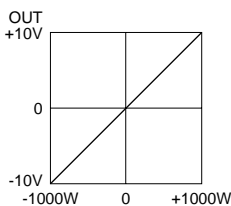
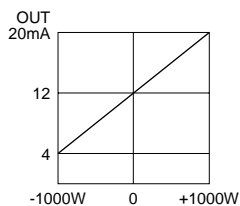
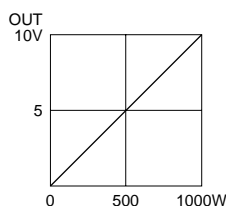
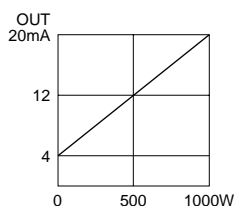

INSTALLATION

Power input

AC: operational voltage range for K3: 85 – 132V or L3: 170 – 264V
47 – 66 Hz, approx. 2VA

DC: operational voltage range for R, V: rating ±10% or P: 85 – 150V; ripple 10% p-p max. approx. 2W (18mA at 110V)

Operating temperature: -10 to +55°C (14 to 131°F)

Operating humidity: 30 to 85% RH (non-condensing)

Mounting: surface or DIN rail

Dimensions: W72×H111×D143* mm (2.83"×4.37"×5.63")

*D147 mm (5.79") with terminal cover

See General Spec. Sheet Figure C-1.

Weight: 450 g (0.99 lbs)

Terminal assignment: See General Spec. Sheet Figure D-1.

PERFORMANCE in percentage of span

Accuracy: ±0.5% (at 23°C ±10°C or 73.4°F ±18°F, 45 – 65 Hz)

Magnetic field (ext. origin) effect: ±0.5% (400A/m)

Response time: ≤2 seconds (0 – 100% ±1%)

Ripple: 0.5% p-p max.**

Line voltage effect: ±0.25% over voltage range

Insulation resistance: ≥100MΩ with 500V DC

Dielectric strength: 2000V AC @1 minute (voltage input to current input to DC output to pulse output to power to ground)

Impulse withstand voltage: 1.2/50 μsec., ±5kV (input to output or ground)

**The output ripple may increase when there is great difference between the frequencies of input signal and power supply.

STANDARDS & APPROVALS

CE conformity: EMC Directive (89/336/EEC)

EMI EN61000-6-4

EMS EN61000-6-2

Low Voltage Directive (73/23/EEC)

EN61010-1

Installation category II

Pollution degree 2

Input to output or power – Reinforced insulation

Max. operating voltage 550V

Output to power – Reinforced insulation

Max. operating voltage 300V

IEC Standard: IEC 60688

CONNECTION DIAGRAM

■ **3-PHASE/3-WIRE**

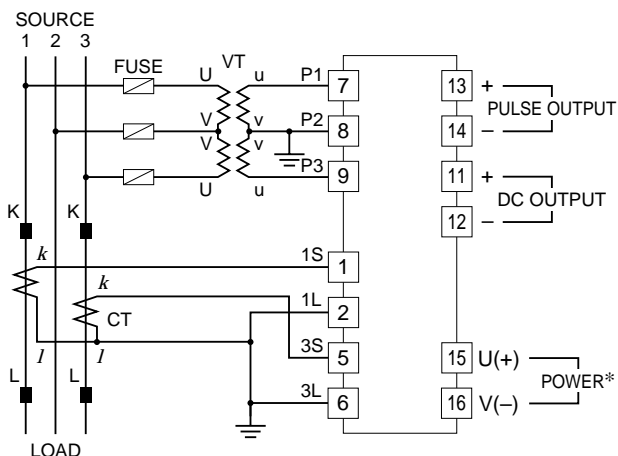

■ **SINGLE-PHASE/2-WIRE**

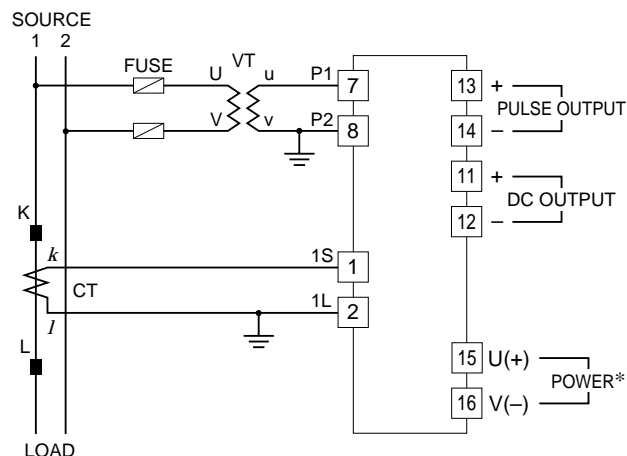

■ **SINGLE-PHASE/3-WIRE**

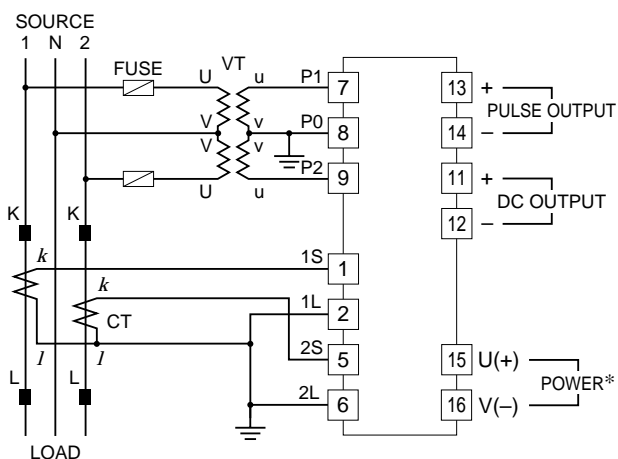

■ **3-PHASE/4-WIRE**

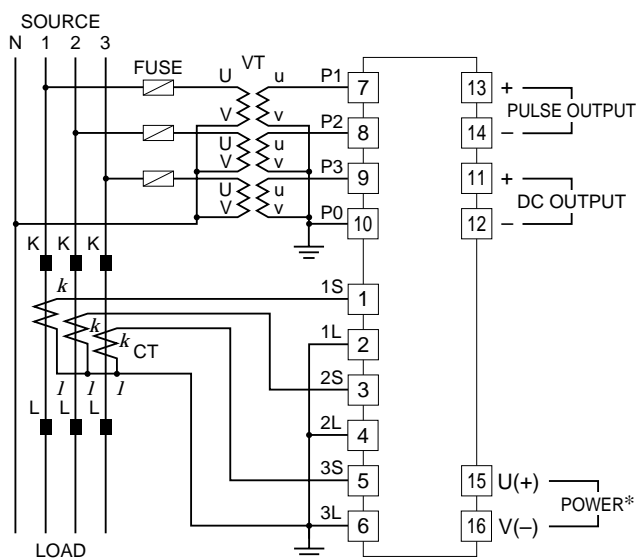

Pulse Output Connection Example

■ Open Collector

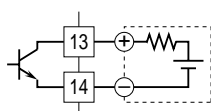

*The transducer can be powered from the input voltage when the voltage is sufficiently stable and meets within the range of auxiliary power supply of the unit specified in the data sheet/instruction manual.