

Plug-in Signal Conditioners M-UNIT

DC ALARM
(dual or quad alarm trip; field-configurable)

MODEL **AS4V**

MODEL & SUFFIX CODE SELECTION

AS4V-□□-□□

MODEL _____
 INPUT _____
Current
Z1 : Range 0 – 50mA DC
Voltage
S1 : Range -1 – +1V DC
S2 : Range -10 – +10V DC
OUTPUT _____
2 : 4 points; N.O. or make contact
3 : 4 points; N.C. or break contact
5 : 2 points; SPDT or transfer contact
POWER INPUT _____
AC Power **DC Power**
M2 : 100 – 240V AC **R** : 24V DC
 P : 110V DC
OPTIONS _____
 /UL : UL approval

ORDERING INFORMATION

Specify code number. (e.g. AS4V-S22-R)

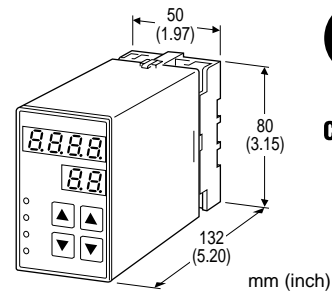

Functions & Features

- Providing relay outputs at preset DC input levels
- Quad or dual trip • Front display indicates values in engineering unit • Setpoint adjustments with the front keypad • Software lock • Adjustable hysteresis (deadband) • On-delay timer • Hi/Lo trip and energized/de-energized coil independently selectable for each setpoint • Enclosed relays • Relays can be powered by 200V AC and 100V DC • High-density mounting on DIN rail

Typical Applications

- Annunciator • Various alarm applications

GENERAL SPECIFICATIONS

Construction: plug-in
Connection: M3.5 screw terminals
Housing material: flame-resistant resin (black)
Isolation (basic insulation): input to output to power
Setpoint adjustments: front key pad
Sampling cycle: 100 millisec.

■DISPLAY

LED: 8 mm (.31") 7 segment, red
Number of display digits: 4 digits for DATA display; 2 digits for ITEM display
Range: -1999 to 9999
 (decimal point position selectable)
PV indication: input signal in engineering unit
Overrange indication: LEDs flashing
Power saving mode: displays turn off if the keys are untouched for a preset time period
LEDs: red lights turn on in tripped conditions

INPUT & OUTPUT

INPUT

• **DC Current:** 0 – 50mA DC; shunt resistor attached to input terminals (100Ω, 0.5W)

Operational range: 0 – 70mA DC (with 100Ω/0.5W)

Minimum increment: 0.1mA

• **DC Voltage:** -1 – +1V DC for S1;
-10 – +10V DC for S2

Operational range: -1.15 – +1.15V DC for S1;
-11.5 – +11.5V DC

Minimum increment: 10mV for S1; 100mV for S2

Input resistance: 1MΩ minimum

OUTPUT

Alarm Trip Operation Example with quad N.O. contacts (LL, L, H, HH); Terminal No. in parentheses

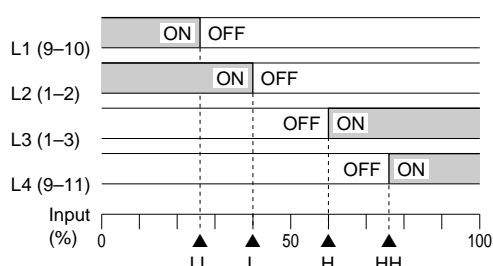

Trip Operation in Power Failure

- **Output Code 2:** all relays turn OFF.
- **Output Code 3:** all relays turn ON.
- **Output Code 5:** Terminals 1 – 3, 9 – 11 turn ON.

•Quad Alarm

Relay rating: 120V AC @1A (cosφ=1)
240V AC @0.5A (cosφ=1)
30V DC @1A (resistive load)
electrical life 10⁵ cycles (rate 30/min.)

Maximum switching voltage: 380V AC or 125V DC

Maximum switching power: 100VA or 30W

Minimum load: 5V DC @10mA

Mechanical life: 5 × 10⁷ cycles

•Dual Alarm

Relay rating: 120V AC @5A (cosφ=1)
240V AC @2.5A (cosφ=1)
30V DC @5A (resistive load)
electrical life 10⁵ cycles (rate 30/min.)

Maximum switching voltage: 380V AC or 125V DC

Maximum switching power: 500VA or 150W

Minimum load: 5V DC @10mA

Mechanical life: 5 × 10⁷ cycles

INSTALLATION

Power input

AC: operational voltage range 85 – 264V;
(90 – 264V for UL);
47 – 66 Hz, approx. 6VA

DC: operational voltage range for R: 24V ±10%
or P: 85 – 150V (110V ±10% for UL);
approx. 3.5W (ripple 10% p-p max.)

Operating temperature: -5 to +55°C (23 to 131°F)

Operating humidity: 30 to 90% RH (non-condensing)

Mounting: surface or DIN rail

Dimensions: W50×H80×D132 mm (1.97"×3.15"×5.20")
See General Spec. Sheet Figure C-2.

Weight: 500 g (1.1 lbs)

Terminal assignment: See General Spec. Sheet Figure D-2.

PERFORMANCE in percentage of FS input

Setpoint accuracy (trip point accuracy):

±(0.1% of FS + 1 digit)

Display accuracy: ±(0.1% of FS + 1 digit)

Temp. coefficient: ±0.015%/°C (±0.008%/°F)

Response time: ≤0.5 seconds (0 – 100% at 90% setpoint)

Line voltage effect: ±0.1% over voltage range

Insulation resistance: ≥100MΩ with 500V DC

Dielectric strength: 2000V AC @1 minute
(input to output to power to ground)

STANDARDS & APPROVALS

CE conformity: EMC Directive (89/336/EEC)

EMI EN61000-6-4

EMS EN61000-6-2

Low Voltage Directive (73/23/EEC)

Installation category II

Pollution degree 2

Max. operating voltage 300V

Input to output to power – Basic insulation

Approval: UL/C-UL general safety requirements

(UL 3111-1, CAN/CSA-C22.2 No.1010-1)

SCHEMATIC CIRCUITRY & CONNECTION DIAGRAM

■ OUTPUT SUFFIX CODE: 2

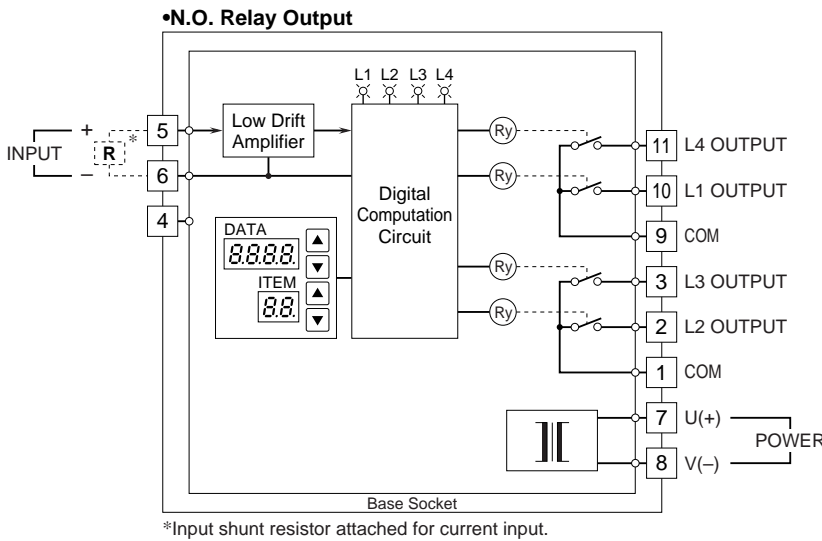

■ OUTPUT SUFFIX CODE: 3

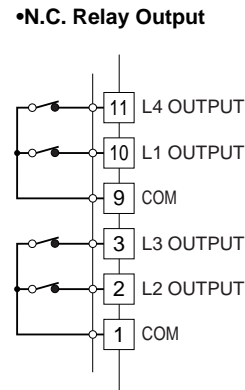

■ OUTPUT SUFFIX CODE: 5

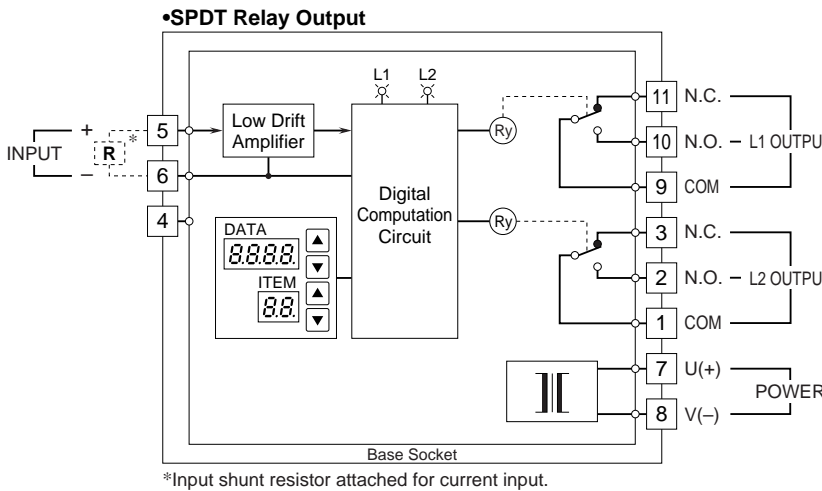

■ Relay Protection

•AC Powered

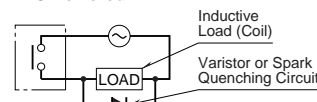

•DC Powered

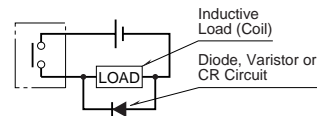

FRONT PANEL CONFIGURATION & PROGRAMMING

■ PROGRAMMING PROCEDURE

1. Press ITEM UP or DOWN key until ITEM display indicates "01".
2. Press DATA UP or DOWN key and choose "1" or "2" on DATA display.
 - 1 : Only alarm setpoints are modifiable.
 - 2 : All parameters are modifiable.
3. Press ITEM UP or DOWN key until ITEM display shows the ITEM No. you need to change.
4. Press DATA UP or DOWN key and choose a DATA No. or value you need on DATA display.
5. Repeat above 3 and 4. (Entered data is stored when you move to a new ITEM.)
6. Press ITEM UP or DOWN key until ITEM display indicates "01".
7. Press DATA UP or DOWN key and choose "0" on the display.
8. Press ITEM UP or DOWN key until ITEM display indicates "P". DATA display shows process input. (You can now check data setting by choosing ITEM No.)

Note: DO NOT press UP and DOWN keys simultaneously.

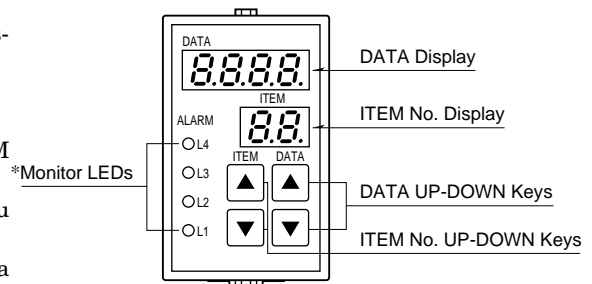

*L3 or L4 does not turn on for dual output type.

ITEM	MDF CODE	DATA	CONTENTS	DEFAULT SETTING
P	N/A	-1999 – 9999	Process input display in engineering unit (as set in ITEM 07/08)	—
L1	1, 2	-1999 – 9999	L1 alarm setpoint in engineering unit	Quad: 20.0 Dual: 20.0
L2	1, 2	-1999 – 9999	L2 alarm setpoint in engineering unit	Quad: 30.0 Dual: 80.0
L3	1, 2	-1999 – 9999	L3 alarm setpoint in engineering unit *1	Quad: 70.0
L4	1, 2	-1999 – 9999	L4 alarm setpoint in engineering unit *1	Quad: 80.0
01		0, 1, 2	Modification code 0 : Data indication only. 1 : Only ITEM L1 – L4 are modifiable. 2 : All parameters are modifiable.	1
02	N/A	0 – 99	Status indication (“0” is normally indicated.) 0: Normal 1: Memory error 10: Out of input range -15 – 115%	
03	N/A	0, 1, 4	Input range 0: S1, 1: S2, 4: Z1	Specified when ordering
04	N/A	-15.0 – 115.0	Input indicated in % (as set in ITEM27, 28)	—
05	2	-19.99 – 99.99	Zero adjustment (%) (fine adj. of the value set in ITEM 27)	0.00
06	2	0.000 – 9.999	Gain adjustment (fine adj. of the value set in ITEM 28)	1.000
07	2	-1999 – 9999	Display range scaling 0% *2	0.0
08	2	-1999 – 9999	Display range scaling 100% *2	100.0
09	2	0, 1, 2, 3	Decimal point position 0 : _ _ _ _ (Specify the number of 1 : _ _ . _ _ digits 2 : _ _ . _ _ 3 : _ . _ _ _	1
10	2	0 – 99	Power ON-delay time (seconds)	5
11	2	0 – 999	Alarm ON-delay time (seconds)	0
12	2	0, 1, 2, 3, 4	Moving average (sampling cycle: 100 msec.) 0: No, 1: 4 samples, 2: 8 samples, 3: 16 samples, 4: 32 samples	0
13	2	0, 1	L1 trip operation (0: Lo, 1: Hi)	Quad: 0 Dual: 0
14	2	0, 1	L2 trip operation (0: Lo, 1: Hi)	Quad: 0 Dual: 1
15	2	0, 1	L3 trip operation (0: Lo, 1: Hi) *1	Quad: 1
16	2	0, 1	L4 trip operation (0: Lo, 1: Hi) *1	Quad: 1
17	2	0, 1 – 60	Power-saving mode 0: Continuous display 1 – 60: Time before display turned off (minutes)	10
18	2	0, 1	L1 coil at alarm (0: Energized, 1: De-energized)	0
19	2	0, 1	L2 coil at alarm (0: Energized, 1: De-energized)	0
20	2	0, 1	L3 coil at alarm (0: Energized, 1: De-energized) *1	0
21	2	0, 1	L4 coil at alarm (0: Energized, 1: De-energized) *1	0
22	N/A	—	Version No. indication	—
23	2	1 – 9999	L1 hysteresis (deadband) in engineering unit	1.0
24	2	1 – 9999	L2 hysteresis (deadband) in engineering unit	1.0
25	2	1 – 9999	L3 hysteresis (deadband) in engineering unit	1.0
26	2	1 – 9999	L4 hysteresis (deadband) in engineering unit	1.0
27	2	S2: -10.0 – 10.0*3	0% input voltage/current (ITEM 27 < ITEM 28)	S1: -1.00V, S2: -10.0V, Z1: 4.0mA
28	2	S2: -10.0 – 10.0*3	100% input voltage/current (ITEM 27 < ITEM 28)	S1: 1.00V, S2: 10.0V, Z1: 20.0mA
29	2	0, 1	Latching control (0: Disabled, 1: Enabled) Selecting “0” resets latching relays. Turning power supply off also resets them.	0
30	—	0000 – 1111	Alarm indication (0: OFF, 1: ON) The MSD indicates the L1, while the LSD indicates the L4.	—

*1: Quad alarm trip type only

*2: Of the range set in ITEM 05/06. ITEM 07 < ITEM 08.

*3: S1-1.00 – 1.00, Z1: 0.0 – 50.0