

**Limit Alarms (rotary switch adj.) AL-UNIT**

**TACHOGENERATOR ALARM**

MODEL **ALTG**

**MODEL & SUFFIX CODE SELECTION**

ALTG-□□□□

MODEL \_\_\_\_\_

INPUT \_\_\_\_\_

- 1 : 0 – 35V AC
- 2 : 0 – 50mV AC
- 3 : 0 – 60mV AC
- 4 : 0 – 100mV AC
- 5 : 0 – 1V AC
- 6 : 0 – 10V AC
- 7 : 0 – 100V AC
- 8 : 0 – 110V AC
- 9 : 0 – 150V AC
- A : 0 – 200V AC
- B : 0 – 250V AC

U : Specify voltage\*

Min. 15 Hz, max. 1 kHz with 100% input

\*0% input must be 0V.

**SETPOINT 1 OUTPUT** \_\_\_\_\_

- 1 : Hi (coil energized at alarm)
- 2 : Hi (coil de-energized at alarm)
- 3 : Lo (coil energized at alarm)
- 4 : Lo (coil de-energized at alarm)

**SETPOINT 2 OUTPUT** \_\_\_\_\_

- 1 : Hi (coil energized at alarm)
- 2 : Hi (coil de-energized at alarm)
- 3 : Lo (coil energized at alarm)
- 4 : Lo (coil de-energized at alarm)

**POWER INPUT** \_\_\_\_\_

**AC Power**

- B : 100V AC
- C : 110V AC
- D : 115V AC
- F : 120V AC

**DC Power**

- G : 200V AC
- H : 220V AC
- J : 240V AC
- S : 12V DC
- R : 24V DC
- V : 48V DC
- P : 110V DC

**ORDERING INFORMATION**

Specify code number and variables.

- Code number (e.g. ALTG-111-B)
- Special input range (For code U)

**GENERAL SPECIFICATIONS**

**Construction:** plug-in

**Connection:** M3.5 screw terminals

**Housing material:** flame-resistant resin (black)

**Isolation:** input to output to power

**Setpoint adjustments:** 10-position rotary switches (front); 0 – 99% independently; 1% increments

**Hysteresis (deadband):** 0.7 – 2.5%

**Front LEDs:** red lights turn on when coils are energized.

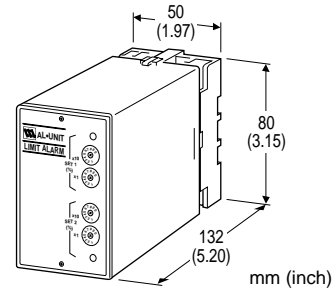

**Functions & Features**

- Providing SPDT relay outputs at preset AC voltage levels from a tachogenerator
- Dual (Hi/Lo) trip
- Energized or de-energized coil at a tripped condition selectable
- Rotary switch setpoint adjustments
- Enclosed relays
- Relays can be powered 110V DC
- High-density mounting

**Typical Applications**

- Annunciator
- Various alarm applications

**Power ON timer:** relays de-energized for approx. 2 seconds after power is turned on.

**INPUT & OUTPUT**

■INPUT: 0 – 250V AC

Minimum span: 50mV

Input resistance: 100kΩ minimum

Frequency: 15 Hz min., 1 kHz max. with 100% input

■OUTPUT

**Alarm Trip Operation** Terminal No. in parentheses

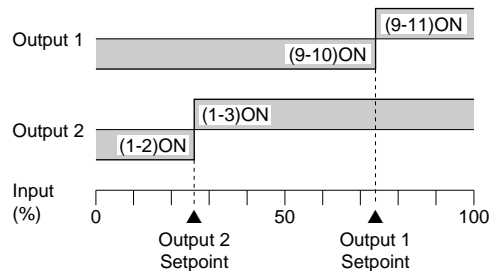

**Trip Operation in Power Failure**

- Output Code: 1 & 4: Terminals 1 – 2, 9 – 10 turn ON
- Output Code: 2 & 3: Terminals 1 – 3, 9 – 11 turn ON

- Relay Contact:** 120V AC @1A ( $\cos\phi=1$ )  
 240V AC @0.5A ( $\cos\phi=1$ )  
 30V DC @1A (resistive load)  
 electrical life  $5 \times 10^5$  cycles (rate 30/min.)
- Maximum switching voltage:** 380V AC or 125V DC
- Maximum switching power:** 100VA or 30W
- Minimum load:** 5V DC @10mA
- Mechanical life:**  $5 \times 10^7$  cycles  
 For maximum relay life with inductive loads, external protection is recommended.

**PERFORMANCE in percentage of span**

- Setpoint accuracy:**  $\pm 0.9\%$
- Trip point repeatability:**  $\pm 0.05\%$
- Temp. coefficient:**  $\pm 0.015\%/^{\circ}\text{C}$  ( $\pm 0.008\%/^{\circ}\text{F}$ )
- Response time:** approx. 0.5 sec. (0 – 100% at 90% setpoint)
- Line voltage effect:**  $\pm 0.1\%$  over voltage range
- Insulation resistance:**  $\geq 100\text{M}\Omega$  with 500V DC
- Dielectric strength:** 2000V AC @1 minute (input to output 1 to output 2 to power to ground)

**INSTALLATION**

- Power input**
  - AC:** rating  $\pm 10\%$ , 50/60  $\pm 2$  Hz, approx. 2VA
  - DC:** rating  $\pm 10\%$ , or 85 – 150V for 110V rating (ripple 10% p-p max.)  
 approx. 2W (80mA at 24V)
- Operating temperature:** -5 to  $+60^{\circ}\text{C}$  (23 to  $140^{\circ}\text{F}$ )
- Operating humidity:** 30 to 90% RH (non-condensing)
- Mounting:** surface or DIN rail
- Dimensions:** W50xH80xD132 mm (1.97"x3.15"x5.20")  
 See General Spec. Sheet Figure A.
- Weight:** 370 g (0.82 lbs)
- Terminal assignment:** See General Spec. Sheet Figure B-1.

**FRONT PANEL CONFIGURATION**

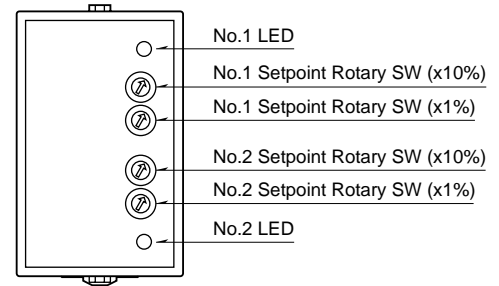

**SCHEMATIC CIRCUITRY & CONNECTION DIAGRAM**

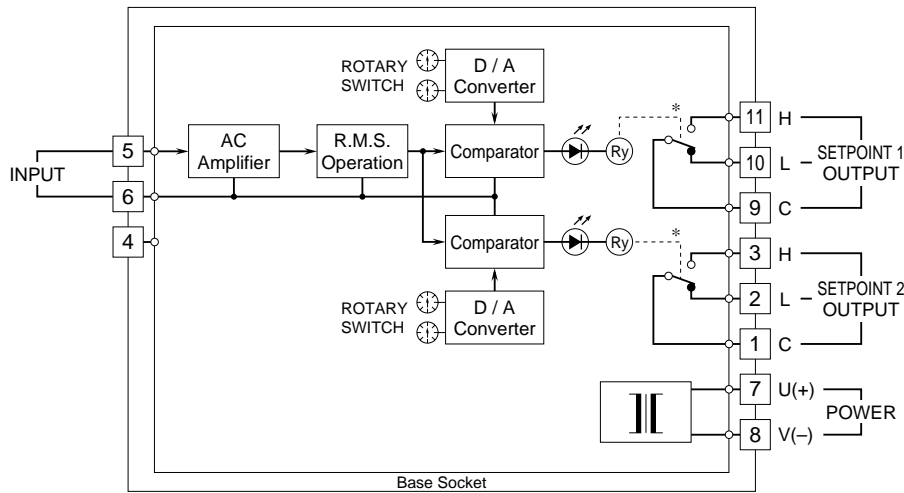

\*Relay status for output codes "1" & "4", at power OFF.

**Relay Protection**  
 •AC Powered

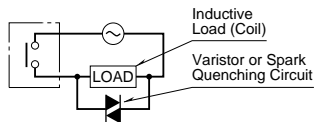

•DC Powered

