

Limit Alarms (rotary switch adj.) AL-UNIT

TWO-WIRE TRANSMITTER ALARM

MODEL **ALDY/ALDN**

MODEL & SUFFIX CODE SELECTION

MODEL _____ **ALD**□-□□-□□

ALDY : Proportional output
ALDN : Square root extracted output

INPUT
 4 – 20mA DC

SETPOINT 1 OUTPUT _____

1 : Hi (coil energized at alarm)
 2 : Hi (coil de-energized at alarm)
 3 : Lo (coil energized at alarm)
 4 : Lo (coil de-energized at alarm)

SETPOINT 2 OUTPUT _____

1 : Hi (coil energized at alarm)
 2 : Hi (coil de-energized at alarm)
 3 : Lo (coil energized at alarm)
 4 : Lo (coil de-energized at alarm)

POWER INPUT _____

AC Power		DC Power
B : 100V AC	G : 200V AC	S : 12V DC
C : 110V AC	H : 220V AC	R : 24V DC
D : 115V AC	J : 240V AC	V : 48V DC
F : 120V AC	P : 110V DC	

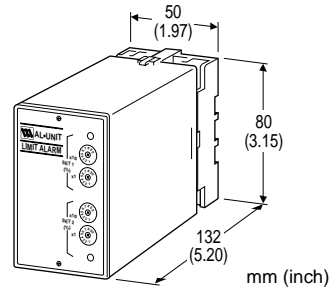

Functions & Features

- Powering a 4 – 20mA DC current loop
- Providing SPDT relay outputs at preset current levels
- Shortcircuit protection
- Square root extraction with model ALDN
- Applicable to smart transmitters
- Dual (Hi/Lo) trip
- Energized or de-energized coil at a tripped condition selectable
- Rotary switch setpoint adjustments
- Enclosed relays
- Relays can be powered 110V DC
- High-density mounting

Typical Applications

- Annunciator
- Various alarm applications

INPUT & OUTPUT

■ **SUPPLY OUTPUT**

Output voltage: 24 – 28V DC with no load
Current rating: 22mA DC maximum

• **Shortcircuit Protection**

Current limited: 30mA maximum
Protected time duration: no limit

■ **INPUT:** 4 – 20mA DC; input resistor incorporated (2W)

Input resistance: 250Ω

■ **OUTPUT**

Alarm Trip Operation Terminal No. in parentheses

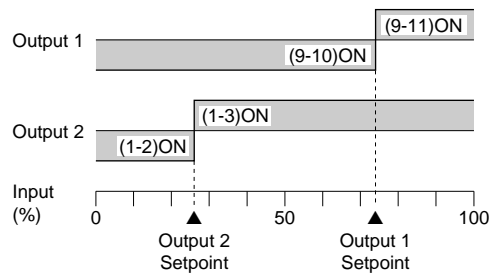

Trip Operation in Power Failure

- **Output Code: 1 & 4:** Terminals 1 – 2, 9 – 10 turn ON
- **Output Code: 2 & 3:** Terminals 1 – 3, 9 – 11 turn ON

ORDERING INFORMATION

Specify code number. (e.g. ALDY-13-B)

GENERAL SPECIFICATIONS

Construction: plug-in
Connection: M3.5 screw terminals
Housing material: flame-resistant resin (black)
Isolation: input to output to power
Setpoint adjustments: 10-position rotary switches (front); 0 – 99% independently; 1% increments

Remark: The ALDN has low-end cutout function below 1% input. A setpoint below 10% output equals 0%.

Hysteresis (deadband): 0.7 – 2.5%
Front LEDs: red lights turn on when coils are energized.
Power ON timer: relays de-energized for approx. 2 seconds after power is turned on.

- Relay Contact:** 120V AC @1A (cosφ=1)
 240V AC @0.5A (cosφ=1)
 30V DC @1A (resistive load)
 electrical life 5×10^5 cycles (rate 30/min.)
- Maximum switching voltage:** 380V AC or 125V DC
- Maximum switching power:** 100VA or 30W
- Minimum load:** 5V DC @10mA
- Mechanical life:** 5×10^7 cycles
 For maximum relay life with inductive loads, external protection is recommended.

PERFORMANCE in percentage of span

- Setpoint accuracy:** $\pm 0.5\%$ (1 – 100% input for ALDN)
- Trip point repeatability:** $\pm 0.05\%$
- Temp. coefficient:** $\pm 0.015\%/^{\circ}\text{C}$ ($\pm 0.008\%/^{\circ}\text{F}$)
- Response time:** approx. 0.7 sec. (0 – 100% at 90% setpoint)
- Line voltage effect:** $\pm 0.1\%$ over voltage range
- Insulation resistance:** $\geq 100\text{M}\Omega$ with 500V DC
- Dielectric strength:** 2000V AC @1 minute (input to output 1 to output 2 to power to ground)

INSTALLATION

- Power input**
 - AC:** rating $\pm 10\%$, 50/60 ± 2 Hz, approx. 2.5VA
 - DC:** rating $\pm 10\%$, or 85 – 150V for 110V rating (ripple 10% p-p max.)
 approx. 2W (80mA at 24V)
- Operating temperature:** -5 to $+60^{\circ}\text{C}$ (23 to 140°F)
- Operating humidity:** 30 to 90% RH (non-condensing)
- Mounting:** surface or DIN rail
- Dimensions:** W50xH80xD132 mm (1.97"x3.15"x5.20")
 See General Spec. Sheet Figure A.
- Weight:** 380 g (0.84 lbs)
- Terminal assignment:** See General Spec. Sheet Figure B-1.

FRONT PANEL CONFIGURATION

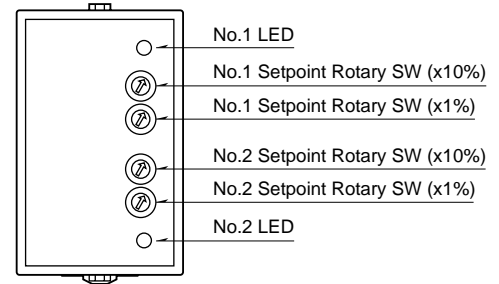

SCHEMATIC CIRCUITRY & CONNECTION DIAGRAM

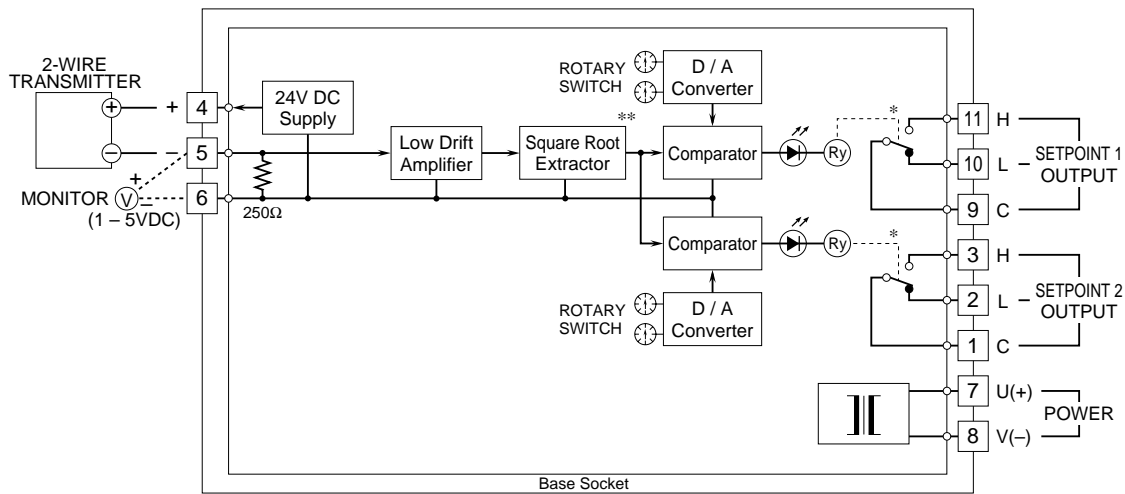

* Relay status for output codes "1" & "4", at power OFF.
 **Deleted with model ALDY

■ **Relay Protection**
 • **AC Powered**

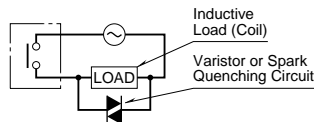

• **DC Powered**

