

Limit Alarms (rotary switch adj.) AL-UNIT

AC ALARM

MODEL **ALAC**

MODEL & SUFFIX CODE SELECTION

MODEL _____ ALAC-□□□□
 INPUT _____
Current **Voltage**
AA : 0 – 10mA AC **A1** : 0 – 100mV AC
AB : 0 – 50mA AC **A2** : 0 – 500mV AC
AC : 0 – 100mA AC **A3** : 0 – 1V AC
AD : 0 – 500mA AC **A4** : 0 – 5V AC
AZ : Specify current* **A5** : 0 – 10V AC
 A6 : 0 – 120V AC
 A7 : 0 – 150V AC
 A8 : Specify voltage*

*0% input must be 0mA or 0V.

SETPOINT 1 OUTPUT

- 1 : Hi (coil energized at alarm)
- 2 : Hi (coil de-energized at alarm)
- 3 : Lo (coil energized at alarm)
- 4 : Lo (coil de-energized at alarm)

SETPOINT 2 OUTPUT

- 1 : Hi (coil energized at alarm)
- 2 : Hi (coil de-energized at alarm)
- 3 : Lo (coil energized at alarm)
- 4 : Lo (coil de-energized at alarm)

POWER INPUT

AC Power		DC Power
B : 100V AC	G : 200V AC	S : 12V DC
C : 110V AC	H : 220V AC	R : 24V DC
D : 115V AC	J : 240V AC	V : 48V DC
F : 120V AC		P : 110V DC

ORDERING INFORMATION

Specify code number and variables.

- Code number (e.g. ALAC-A811-B)
- Special input range (For codes AZ & A8)

GENERAL SPECIFICATIONS

Construction: plug-in
Connection: M3.5 screw terminals
Housing material: flame-resistant resin (black)
Isolation: input to output to power
Input waveform: up to 15% of 3rd harmonic content
Setpoint adjustments: 10-position rotary switches
 (front); 0 – 99% independently; 1% increments
Hysteresis (deadband): 0.7 – 2.5%
Front LEDs: red lights turn on when coils are energized.
Power ON timer: relays de-energized for approx. 2 seconds after power is turned on.

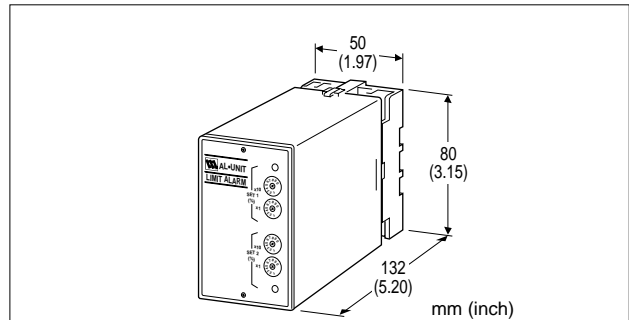

Functions & Features

- Providing SPDT relay outputs at preset AC current/voltage levels
- True RMS sensing
- Dual (Hi/Lo) trip
- Energized or de-energized coil at a tripped condition selectable
- Rotary switch setpoint adjustments
- Enclosed relays
- Relays can be powered 110V DC
- High-density mounting

Typical Applications

- Annunciator
- Various alarm applications

INPUT & OUTPUT

■INPUT

Frequency: 40 Hz min., 1 kHz max. with 100% input
AC Current: 0 – 1A AC; input resistor (2W) incorporated

Minimum span: 1mA

Input resistance

Input	Input Resistance
1mA	: 1k (Ω)
≤2mA	: 500
≤5mA	: 200
≤10mA	: 100
≤20mA	: 50
≤50mA	: 20
≤100mA	: 10
≤500mA	: 1
≤1A	: 0.5

•AC Voltage: 0 – 250V AC

Minimum span: 50mV

Input resistance: 100kΩ minimum

■OUTPUT

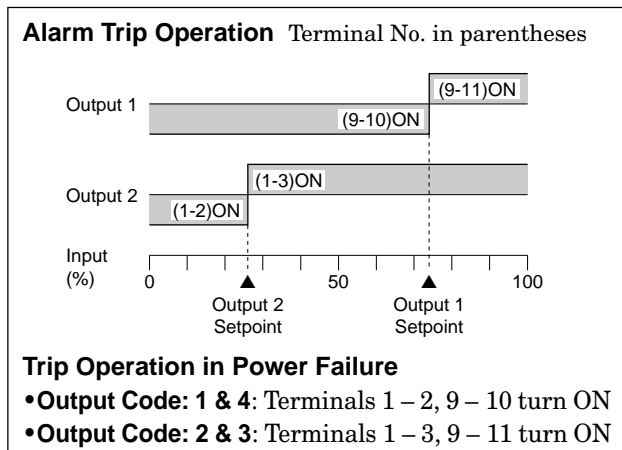

- Relay Contact: 120V AC @1A (cosφ=1)
240V AC @0.5A (cosφ=1)
30V DC @1A (resistive load)
electrical life 5×10^5 cycles (rate 30/min.)
- Maximum switching voltage:** 380V AC or 125V DC
- Maximum switching power:** 100VA or 30W
- Minimum load:** 5V DC @10mA
- Mechanical life:** 5×10^7 cycles
- For maximum relay life with inductive loads, external protection is recommended.

INSTALLATION

Power input

- AC: rating $\pm 10\%$, 50/60 ± 2 Hz, approx. 2VA
- DC: rating $\pm 10\%$, or 85 – 150V for 110V rating (ripple 10% p-p max.)
approx. 2W (80mA at 24V)

- Operating temperature:** -5 to +60°C (23 to 140°F)
- Operating humidity:** 30 to 90% RH (non-condensing)
- Mounting:** surface or DIN rail
- Dimensions:** W50×H80×D132 mm (1.97"×3.15"×5.20")
See General Spec. Sheet Figure A.
- Weight:** 370 g (0.82 lbs)
- Terminal assignment:** See General Spec. Sheet Figure B-1.

PERFORMANCE in percentage of span

- Setpoint accuracy:** $\pm 0.9\%$
- Trip point repeatability:** $\pm 0.05\%$
- Temp. coefficient:** $\pm 0.015\%/^{\circ}\text{C}$ ($\pm 0.008\%/^{\circ}\text{F}$)
- Response time:** approx. 0.7 sec. (0 – 100% at 90% setpoint)
- Line voltage effect:** $\pm 0.1\%$ over voltage range
- Insulation resistance:** $\geq 100\text{M}\Omega$ with 500V DC
- Dielectric strength:** 2000V AC @1 minute (input to output 1 to output 2 to power to ground)

FRONT PANEL CONFIGURATION

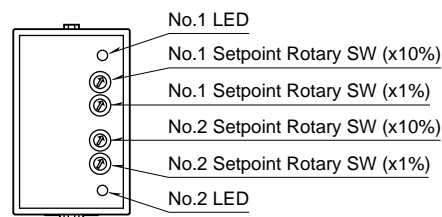

SCHEMATIC CIRCUITRY & CONNECTION DIAGRAM

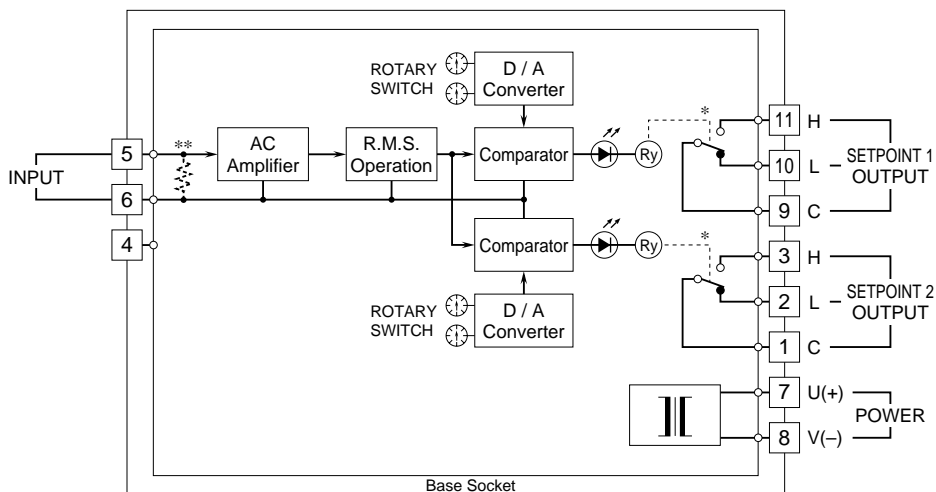

* Relay status for output codes "1" & "4", at power OFF.
**Input resistor incorporated for current input.

■Relay Protection

•AC Powered

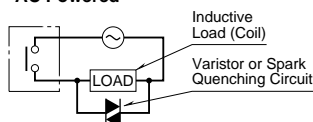

•DC Powered

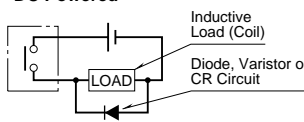

Specifications subject to change without notice.