

**Limit Alarms (with DC output) AE-UNIT**

**FREQUENCY ALARM**

MODEL **AESP**

**MODEL & SUFFIX CODE SELECTION**

AESP-□□□□□□□□

MODEL \_\_\_\_\_

INPUT \_\_\_\_\_

- 1 : Dry contact
- 2 : Voltage pulse

DC OUTPUT \_\_\_\_\_

N : None

Current

Voltage

- |                     |                     |
|---------------------|---------------------|
| A : 4 – 20mA DC     | 1 : 0 – 10mV DC     |
| B : 2 – 10mA DC     | 2 : 0 – 100mV DC    |
| C : 1 – 5mA DC      | 3 : 0 – 1V DC       |
| D : 0 – 20mA DC     | 4 : 0 – 10V DC      |
| E : 0 – 16mA DC     | 5 : 0 – 5V DC       |
| F : 0 – 10mA DC     | 6 : 1 – 5V DC       |
| G : 0 – 1mA DC      | 4W : -10 – +10V DC  |
| Z : Specify current | 5W : -5 – +5V DC    |
|                     | 0 : Specify voltage |

SETPOINT 1 OUTPUT \_\_\_\_\_

- 1 : Hi (coil energized at alarm)
- 2 : Hi (coil de-energized at alarm)
- 3 : Lo (coil energized at alarm)
- 4 : Lo (coil de-energized at alarm)

SETPOINT 2 OUTPUT \_\_\_\_\_

- 1 : Hi (coil energized at alarm)
- 2 : Hi (coil de-energized at alarm)
- 3 : Lo (coil energized at alarm)
- 4 : Lo (coil de-energized at alarm)

ON DELAY TIME \_\_\_\_\_

- |                 |               |
|-----------------|---------------|
| 0 : 0.5 seconds | 3 : 3 seconds |
| 1 : 1 second    | 4 : 4 seconds |
| 2 : 2 seconds   |               |

POWER ON DELAY TIME \_\_\_\_\_

- |               |               |
|---------------|---------------|
| 1 : 1 second  | 4 : 4 seconds |
| 2 : 2 seconds | 5 : 5 seconds |
| 3 : 3 seconds |               |

POWER INPUT \_\_\_\_\_

AC Power

DC Power

- |             |             |             |
|-------------|-------------|-------------|
| B : 100V AC | G : 200V AC | S : 12V DC  |
| C : 110V AC | H : 220V AC | R : 24V DC  |
| D : 115V AC | J : 240V AC | V : 48V DC  |
| F : 120V AC |             | P : 110V DC |

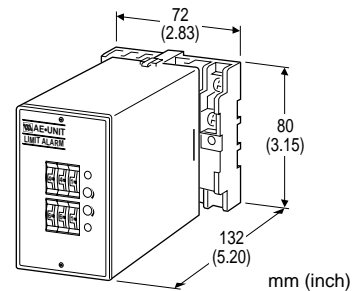

**Functions & Features**

- Providing SPDT relay outputs at preset frequency levels
- Dual (Hi/Lo) trip
- Additional isolated DC output proportional to the input
- Low-end cutout
- Energized or de-energized coil at a tripped condition selectable
- Thumbwheel switch adjustments
- Relays can be powered 110V DC

**ORDERING INFORMATION**

Specify code number and variables.

- **Code number** (e.g. AESP-2A2101-B)
- **Frequency range** (e.g. 0 – 500 Hz)
- **Special DC output range** (For codes Z & 0)

**GENERAL SPECIFICATIONS**

**Construction:** plug-in

**Connection:** M3.5 screw terminals

**Housing material:** flame-resistant resin (black)

**Isolation:** input to DC output to relay output to power

**Zero/span adjustments:** ±5% (front)

**Setpoint adjustments:** thumbwheel switches (front); 0 – 99% independently; 1% increments

Remark: The AESP has low-end cutout function below 2 – 5% input. A setpoint below this equals 0%.

**Hysteresis (deadband) adjustments:** thumbwheel switches (front); 0.5, 1 – 9% independently; 1% increments (SW position 0 = 0.5); [Lo SP + Hysteresis] ≤ 102

**Front LEDs:** red lights turn on when coils are energized.

**Low-end cutout:** 2 – 5%

**INPUT & OUTPUT****INPUT**

**Frequency range:** 0 – 50 Hz through 10 kHz

**Pulse width (time) requirement:** duty ratio 20 – 80% at 100% input

• **Dry Contact:** mechanical contact or open collector

**Sensing:** approx. 7.5V DC @1mA

**ON/OFF level:**  $\leq 200\Omega$  for ON,  $\geq 100k\Omega$  for OFF

• **Voltage Pulse:** square or sine waveforms

**Input amplitude:** 2 – 50V p-p

**Input impedance:** 100k $\Omega$  minimum

**DC OUTPUT**

• **DC Current:** 0 – 20mA DC

**Minimum span:** 1mA

**Zero suppression/elevation:** max. 1.5 times span

**Load resistance:** output drive 7V maximum

Output	Load Resistance
4 – 20mA	: 350 ( $\Omega$ maximum)
2 – 10mA	: 700
1 – 5mA	: 1400
0 – 20mA	: 350
0 – 16mA	: 430
0 – 10mA	: 700
0 – 1mA	: 7000

• **DC Voltage:** -10 – +12V DC

**Minimum span:** 5mV

**Zero suppression/elevation:** max. 1.5 times span

**Load resistance:** output drive 1mA maximum; at  $\geq 0.5V$

Output	Load Resistance
0 – 10mV	: 10k ( $\Omega$ minimum)
0 – 100mV	: 100k
0 – 1V	: 1000
0 – 10V	: 10k
0 – 5V	: 5000
1 – 5V	: 5000
-10 – +10V	: 10k
-5 – +5V	: 5000

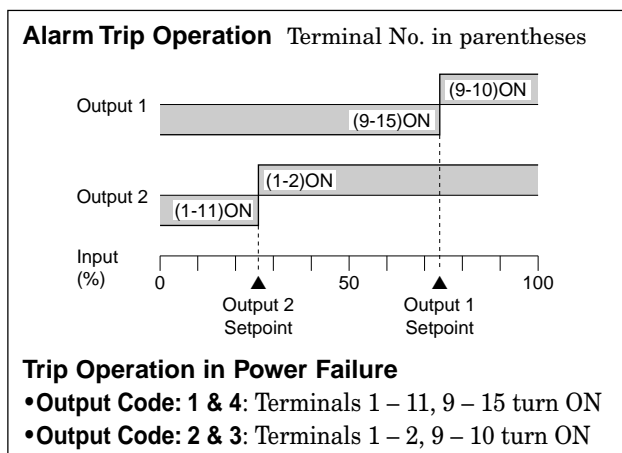
**ALARM OUTPUT**

• **Relay Contact:** 120V AC @1A ( $\cos\phi=1$ )

240V AC @0.5A ( $\cos\phi=1$ )

30V DC @1A (resistive load)

electrical life  $5 \times 10^5$  cycles (rate 30/min.)

**Maximum switching voltage:** 380V AC or 125V DC

**Maximum switching power:** 100VA or 30W

**Minimum load:** 5V DC @10mA

**Mechanical life:**  $5 \times 10^7$  cycles

For maximum relay life with inductive loads, external protection is recommended.

**INSTALLATION****Power input**

**AC:** operational voltage range: rating  $\pm 10\%$ , 50/60  $\pm 2$  Hz, approx. 3VA

**DC:** operational voltage range: rating  $\pm 10\%$ , or 85 – 150V for 110V rating; ripple 10% p-p max.; approx. 2W (80mA at 24V)

**Operating temperature:** -5 to +55°C (23 to 131°F)

**Operating humidity:** 30 to 90% RH (non-condensing)

**Mounting:** surface or DIN rail

**Dimensions:** W72×H80×D132 mm (2.83"×3.15"×5.20")  
See General Spec. Sheet Figure A-1.

**Weight:** 450 g (0.99 lbs)

**Terminal assignment:** See General Spec. Sheet Figure B-1.

**PERFORMANCE in percentage of span****DC output**

**Accuracy:**  $\pm 0.3\%$  (input 10 – 100%)

**Response time:** (0 – 90%)

approx. 2 seconds for 0 – 50 Hz

approx. 1 second for 0 – 100 Hz

approx. 0.5 seconds for 0 – 500 Hz

approx. 0.5 seconds for 0 – 10 kHz

**Alarm output**

**Setpoint accuracy:**  $\pm 0.8\%$  (input 10 – 100%)

**Hysteresis setpoint accuracy:**  $\pm 0.3\%$

**ON delay time accuracy:** DC output response + rating  $\pm 20\%$  or 0.3 sec., whichever is greater.

**Power ON delay time accuracy:** rating  $\pm 30\%$

**Trip point repeatability:**  $\pm 0.05\%$

**Temp. coefficient:**  $\pm 0.015\%/^{\circ}\text{C}$  ( $\pm 0.008\%/^{\circ}\text{F}$ )

**Line voltage effect:**  $\pm 0.1\%$  over voltage range

**Insulation resistance:**  $\geq 100M\Omega$  with 500V DC

**Dielectric strength:** 2000V AC @1 minute

(input to DC output to alarm output 1 to alarm output 2 to power to ground)

# FRONT PANEL CONFIGURATION

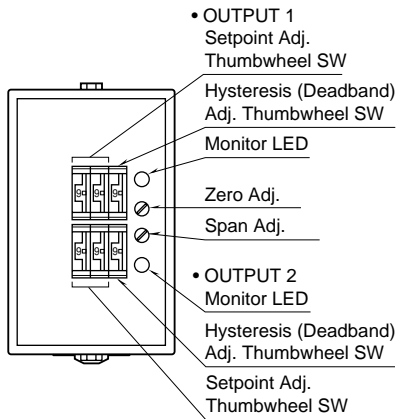

# SCHEMATIC CIRCUITRY & CONNECTION DIAGRAM

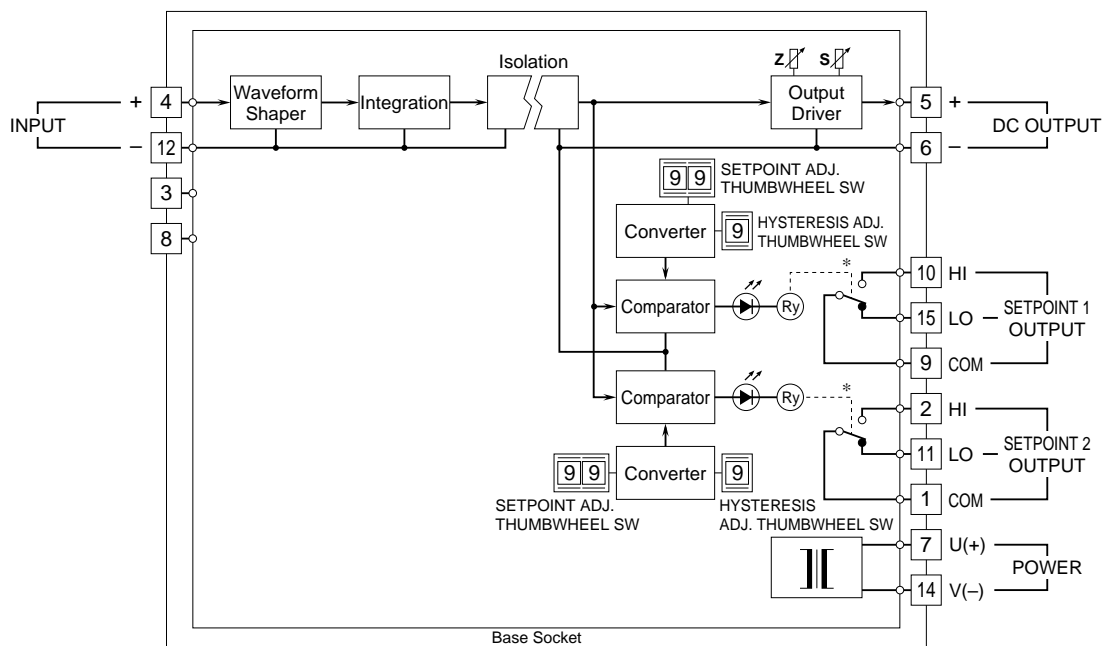

\*Relay status for output codes "1" & "4", at power OFF.

### Input Connection Examples

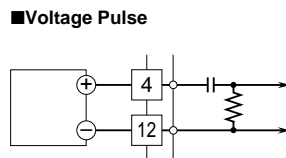
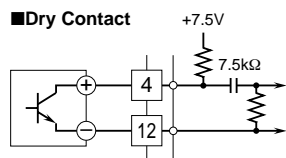

### Relay Protection

