

**Limit Alarms (with DC output) AE-UNIT**

**RTD ALARM**

MODEL

**AER**

**MODEL & SUFFIX CODE SELECTION**

AER-□□□□□□□□

MODEL

INPUT RTD (2- or 3-wire)

- 1 : JPt 100 (JIS '89)
- 3 : Pt 100 (JIS '89)
- 4 : Pt 100 (JIS '97, DIN, IEC751)
- 5 : Pt 50Ω (JIS '81)
- 6 : Ni 508.4Ω

0 : Specify

DC OUTPUT

N : None

Current

Voltage

- |                     |                     |
|---------------------|---------------------|
| A : 4 – 20mA DC     | 1 : 0 – 10mV DC     |
| B : 2 – 10mA DC     | 2 : 0 – 100mV DC    |
| C : 1 – 5mA DC      | 3 : 0 – 1V DC       |
| D : 0 – 20mA DC     | 4 : 0 – 10V DC      |
| E : 0 – 16mA DC     | 5 : 0 – 5V DC       |
| F : 0 – 10mA DC     | 6 : 1 – 5V DC       |
| G : 0 – 1mA DC      | 4W : -10 – +10V DC  |
| Z : Specify current | 5W : -5 – +5V DC    |
|                     | 0 : Specify voltage |

SETPOINT 1 OUTPUT

- 1 : Hi (coil energized at alarm)
- 2 : Hi (coil de-energized at alarm)
- 3 : Lo (coil energized at alarm)
- 4 : Lo (coil de-energized at alarm)

SETPOINT 2 OUTPUT

- 1 : Hi (coil energized at alarm)
- 2 : Hi (coil de-energized at alarm)
- 3 : Lo (coil energized at alarm)
- 4 : Lo (coil de-energized at alarm)

ON DELAY TIME

- |                 |               |
|-----------------|---------------|
| 0 : 0.5 seconds | 3 : 3 seconds |
| 1 : 1 second    | 4 : 4 seconds |
| 2 : 2 seconds   |               |

POWER ON DELAY TIME

- |               |               |
|---------------|---------------|
| 1 : 1 second  | 4 : 4 seconds |
| 2 : 2 seconds | 5 : 5 seconds |
| 3 : 3 seconds |               |

POWER INPUT

AC Power

DC Power

- |             |             |             |
|-------------|-------------|-------------|
| B : 100V AC | G : 200V AC | S : 12V DC  |
| C : 110V AC | H : 220V AC | R : 24V DC  |
| D : 115V AC | J : 240V AC | V : 48V DC  |
| F : 120V AC |             | P : 110V DC |

OPTIONS

/BL : Downscale burnout

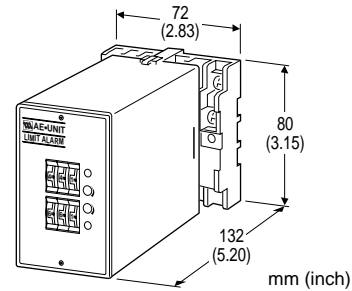

**Functions & Features**

- Providing SPDT relay outputs at preset input levels
- Direct input from an RTD
- Dual (Hi/Lo) trip
- Additional isolated DC output proportional to the temperature
- Linearization
- Burnout protection
- "Active bridge" circuit containing two constant current sources allows large leadwire resistances up to 200Ω
- Energized or de-energized coil at a tripped condition selectable
- Thumbwheel switch adjustments
- Relays can be powered 110V DC

**ORDERING INFORMATION**

Specify code number and variables.

- **Code number** (e.g. AER-4A2101-B/BL)
- **Temperature range** (e.g. 0 – 200°C)
- **Special DC output range** (For codes Z & 0)

**GENERAL SPECIFICATIONS**

**Construction:** plug-in

**Connection:** M3.5 screw terminals

**Housing material:** flame-resistant resin (black)

**Isolation:** input to DC output to relay output to power

**Zero/span adjustments:** ±5% (front)

**Setpoint adjustments:** thumbwheel switches (front); 0 – 99% independently; 1% increments

**Hysteresis (deadband) adjustments:** thumbwheel switches (front); 0.5, 1 – 9% independently; 1% increments (SW position 0 = 0.5); [Lo SP + Hysteresis] ≤ 102

**Front LEDs:** red lights turn on when coils are energized.

**Burnout protection:** upscale standard; downscale optional;  
Both DC and relay outputs respond respectively for upscale input.

**Linearization:** standard

**INPUT & OUTPUT**

■INPUT: 2- or 3-wire RTDs  
**Maximum leadwire resistance:** 200Ω per wire (3-wire)  
**Sensing current:** 2mA (Pt)  
**Temperature range**

RTD	USABLE RANGE		MIN. SPAN	
	°C	°F	°C	°F
JPt 100 (JIS '89)	-200 to +500	-328 to +932	50	90
Pt 100 (JIS '89)	-200 to +650	-328 to +1202	50	90
Pt 100 (JIS '97/DIN/IEC)	-200 to +650	-328 to +1202	50	90
Pt 50Ω (JIS '81)	-200 to +500	-328 to +932	100	180
Ni 508.4Ω	-50 to +200	-58 to +392	30	54

■DC OUTPUT

•DC Current: 0 – 20mA DC  
**Minimum span:** 1mA  
**Zero suppression/elevation:** max. 1.5 times span  
**Load resistance:** output drive 7V maximum

Output	Load Resistance
4 – 20mA	: 350 (Ω maximum)
2 – 10mA	: 700
1 – 5mA	: 1400
0 – 20mA	: 350
0 – 16mA	: 430
0 – 10mA	: 700
0 – 1mA	: 7000

•DC Voltage: -10 – +12V DC  
**Minimum span:** 5mV  
**Zero suppression/elevation:** max. 1.5 times span  
**Load resistance:** output drive 1mA maximum; at ≥0.5V

Output	Load Resistance
0 – 10mV	: 10k (Ω minimum)
0 – 100mV	: 100k
0 – 1V	: 1000
0 – 10V	: 10k
0 – 5V	: 5000
1 – 5V	: 5000
-10 – +10V	: 10k
-5 – +5V	: 5000

■ALARM OUTPUT

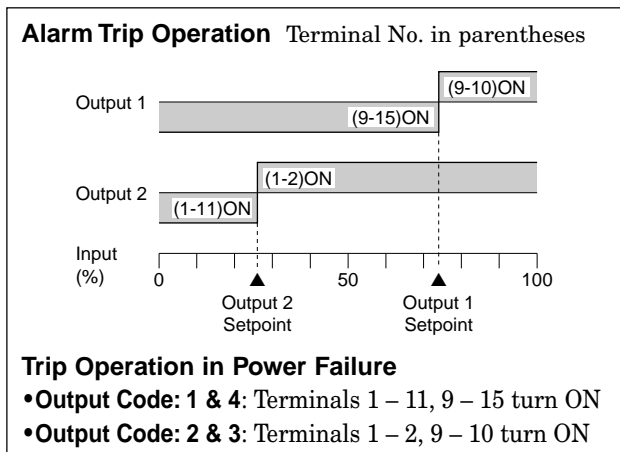

•Relay Contact: 120V AC @1A (cosφ=1)  
 240V AC @0.5A (cosφ=1)  
 30V DC @1A (resistive load)  
 electrical life 5 × 10<sup>5</sup> cycles (rate 30/min.)  
**Maximum switching voltage:** 380V AC or 125V DC  
**Maximum switching power:** 100VA or 30W  
**Minimum load:** 5V DC @10mA  
**Mechanical life:** 5 × 10<sup>7</sup> cycles  
 For maximum relay life with inductive loads, external protection is recommended.

**INSTALLATION**

**Power input**

**AC:** operational voltage range: rating ±10%,  
 50/60 ±2 Hz, approx. 3VA  
**DC:** operational voltage range: rating ±10%, or  
 85 – 150V for 110V rating; ripple 10% p-p  
 max.; approx. 2W (80mA at 24V)

**Operating temperature:** -5 to +55°C (23 to 131°F)  
**Operating humidity:** 30 to 90% RH (non-condensing)  
**Mounting:** surface or DIN rail  
**Dimensions:** W72×H80×D132 mm (2.83"×3.15"×5.20")  
 See General Spec. Sheet Figure A-1.  
**Weight:** 450 g (0.99 lbs)  
**Terminal assignment:** See General Spec. Sheet Figure B-1.

**PERFORMANCE in percentage of span**

**DC output**

**Accuracy:** ±0.2%  
**Response time:** ≤0.5 seconds (0 – 90%)

**Alarm output**

**Setpoint accuracy:** ±0.7%  
**Hysteresis setpoint accuracy:** ±0.3%  
**ON delay time accuracy:** rating ±20% or 0.3 sec.,  
 whichever is greater.  
**Power ON delay time accuracy:** rating ±30%  
**Trip point repeatability:** ±0.05%

**Temp. coefficient:** ±0.015%/°C (±0.008%/°F)

**Burnout response:** ≤10 seconds

**Line voltage effect:** ±0.1% over voltage range

**Insulation resistance:** ≥100MΩ with 500V DC

**Dielectric strength:** 2000V AC @1 minute

(input to DC output to alarm output 1 to  
 alarm output 2 to power to ground)

# FRONT PANEL CONFIGURATION

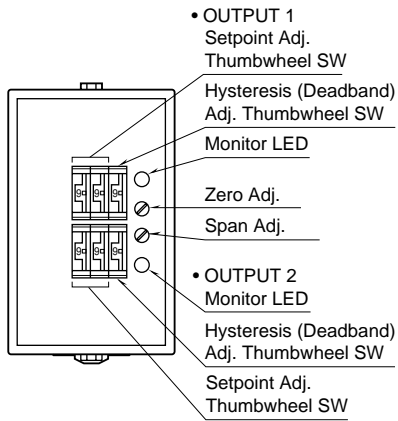

# SCHEMATIC CIRCUITRY & CONNECTION DIAGRAM

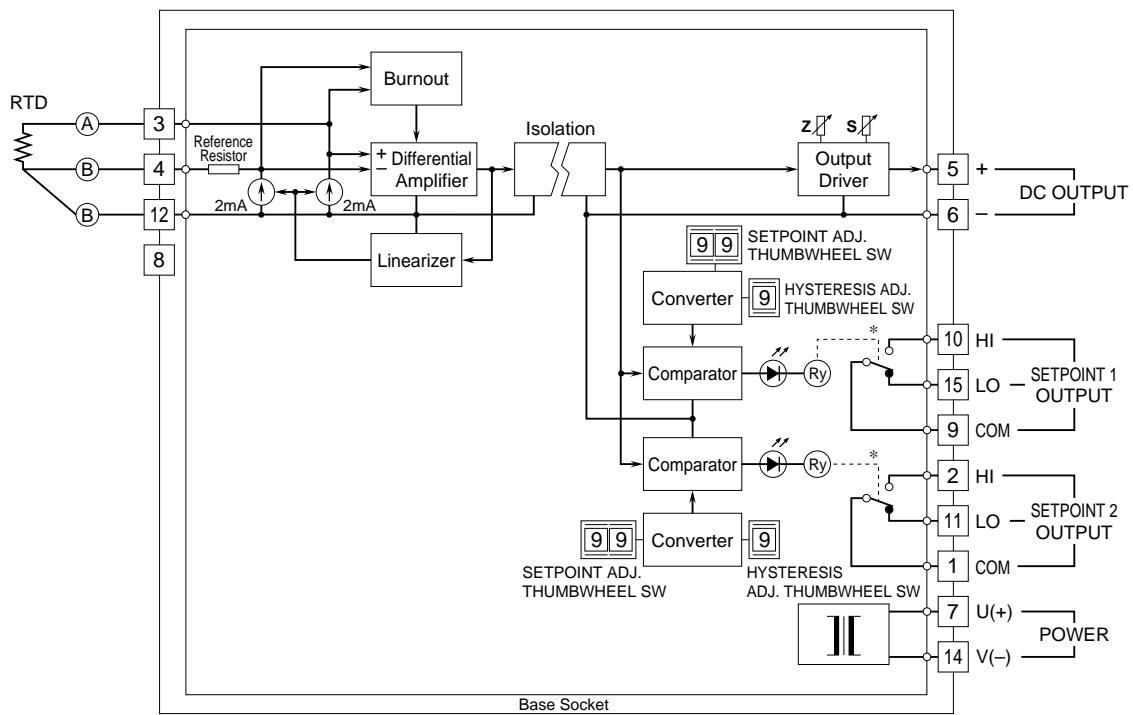

\*Relay status for output codes "1" & "4", at power OFF.

### Relay Protection

#### AC Powered

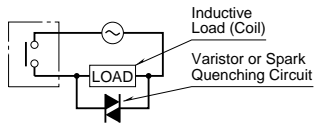

#### DC Powered

