

**Limit Alarms (with DC output) AE-UNIT**

**POTENTIOMETER ALARM**

MODEL **AEM**

**MODEL & SUFFIX CODE SELECTION**

MODEL \_\_\_\_\_ AEM-□□□□□□

INPUT \_\_\_\_\_

Total resistance 100Ω – 10kΩ

**DC OUTPUT**

N : None

<b>Current</b>	<b>Voltage</b>
A : 4 – 20mA DC	1 : 0 – 10mV DC
B : 2 – 10mA DC	2 : 0 – 100mV DC
C : 1 – 5mA DC	3 : 0 – 1V DC
D : 0 – 20mA DC	4 : 0 – 10V DC
E : 0 – 16mA DC	5 : 0 – 5V DC
F : 0 – 10mA DC	6 : 1 – 5V DC
G : 0 – 1mA DC	4W : -10 – +10V DC
Z : Specify current	5W : -5 – +5V DC
	0 : Specify voltage

**SETPOINT 1 OUTPUT** \_\_\_\_\_

1 : Hi (coil energized at alarm)

2 : Hi (coil de-energized at alarm)

3 : Lo (coil energized at alarm)

4 : Lo (coil de-energized at alarm)

**SETPOINT 2 OUTPUT** \_\_\_\_\_

1 : Hi (coil energized at alarm)

2 : Hi (coil de-energized at alarm)

3 : Lo (coil energized at alarm)

4 : Lo (coil de-energized at alarm)

**ON DELAY TIME** \_\_\_\_\_

0 : 0.5 seconds	3 : 3 seconds
1 : 1 second	4 : 4 seconds
2 : 2 seconds	

**POWER ON DELAY TIME** \_\_\_\_\_

1 : 1 second	4 : 4 seconds
2 : 2 seconds	5 : 5 seconds
3 : 3 seconds	

**POWER INPUT** \_\_\_\_\_

<b>AC Power</b>	<b>DC Power</b>	
B : 100V AC	G : 200V AC	S : 12V DC
C : 110V AC	H : 220V AC	R : 24V DC
D : 115V AC	J : 240V AC	V : 48V DC
F : 120V AC		P : 110V DC

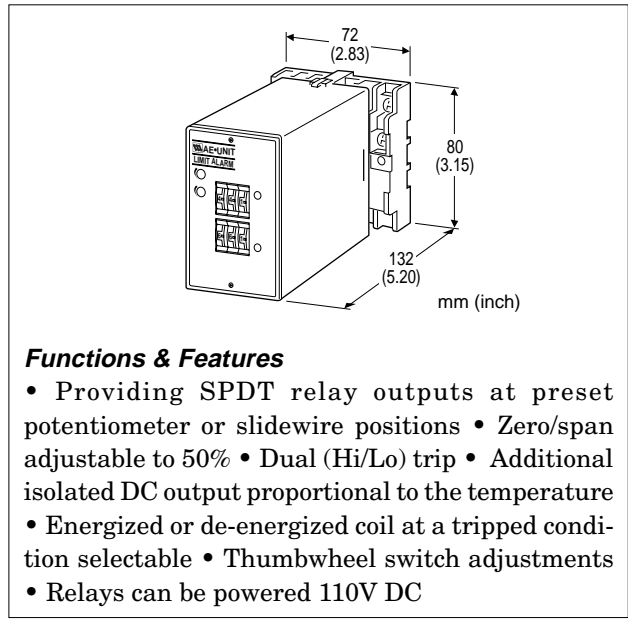

**GENERAL SPECIFICATIONS**

**Construction:** plug-in

**Connection:** M3.5 screw terminals

**Housing material:** flame-resistant resin (black)

**Isolation:** input to DC output to relay output to power

**Zero/span adjustments:** 0 – 50% of total resistance for zero; 50 – 100% for span (front)

**Setpoint adjustments:** thumbwheel switches (front); 0 – 99% independently; 1% increments

**Hysteresis (deadband) adjustments:** thumbwheel switches (front); 0.5, 1 – 9% independently; 1% increments (SW position 0 = 0.5); [Lo SP + Hysteresis] ≤ 102

**Front LEDs:** red lights turn on when coils are energized.

**INPUT & OUTPUT**

■ **INPUT:** potentiometer; 100Ω – 10kΩ

**Minimum span:** 50% of total resistance

**Excitation:** 0.5V DC

**ORDERING INFORMATION**

Specify code number and variables.

- **Code number** (e.g. AEM-A2101-B)
- **Special DC output range** (For codes Z & 0)

### ■DC OUTPUT

•DC Current: 0 – 20mA DC

Minimum span: 1mA

Zero suppression/elevation: max. 1.5 times span

Load resistance: output drive 7V maximum

Output	Load Resistance
4 – 20mA	: 350 ( $\Omega$ maximum)
2 – 10mA	: 700
1 – 5mA	: 1400
0 – 20mA	: 350
0 – 16mA	: 430
0 – 10mA	: 700
0 – 1mA	: 7000

•DC Voltage: -10 – +12V DC

Minimum span: 5mV

Zero suppression/elevation: max. 1.5 times span

Load resistance: output drive 1mA maximum; at  $\geq 0.5V$

Output	Load Resistance
0 – 10mV	: 10k ( $\Omega$ minimum)
0 – 100mV	: 100k
0 – 1V	: 1000
0 – 10V	: 10k
0 – 5V	: 5000
1 – 5V	: 5000
-10 – +10V	: 10k
-5 – +5V	: 5000

### ■ALARM OUTPUT

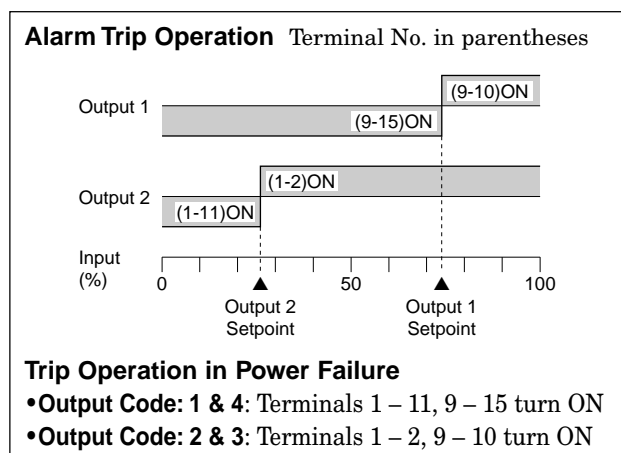

•Relay Contact: 120V AC @1A ( $\cos\phi=1$ )

240V AC @0.5A ( $\cos\phi=1$ )

30V DC @1A (resistive load)

electrical life  $5 \times 10^5$  cycles (rate 30/min.)

Maximum switching voltage: 380V AC or 125V DC

Maximum switching power: 100VA or 30W

Minimum load: 5V DC @10mA

Mechanical life:  $5 \times 10^7$  cycles

For maximum relay life with inductive loads, external protection is recommended.

### INSTALLATION

#### Power input

AC: operational voltage range: rating  $\pm 10\%$ ,  
50/60  $\pm 2$  Hz, approx. 3VA

DC: operational voltage range: rating  $\pm 10\%$ , or  
85 – 150V for 110V rating; ripple 10% p-p  
max.; approx. 2W (80mA at 24V)

Operating temperature: -5 to +55°C (23 to 131°F)

Operating humidity: 30 to 90% RH (non-condensing)

Mounting: surface or DIN rail

Dimensions: W72×H80×D132 mm (2.83"×3.15"×5.20")  
See General Spec. Sheet Figure A-1.

Weight: 450 g (0.99 lbs)

Terminal assignment: See General Spec. Sheet Figure B-1.

### PERFORMANCE in percentage of span

#### DC output

Accuracy:  $\pm 0.1\%$

Response time:  $\leq 0.5$  seconds (0 – 90%)

#### Alarm output

Setpoint accuracy:  $\pm 0.5\%$

Hysteresis setpoint accuracy:  $\pm 0.3\%$

ON delay time accuracy: rating  $\pm 20\%$  or 0.3 sec.,  
whichever is greater.

Power ON delay time accuracy: rating  $\pm 30\%$

Trip point repeatability:  $\pm 0.05\%$

Temp. coefficient:  $\pm 0.015\%/^{\circ}\text{C}$  ( $\pm 0.008\%/^{\circ}\text{F}$ )

Line voltage effect:  $\pm 0.1\%$  over voltage range

Insulation resistance:  $\geq 100M\Omega$  with 500V DC

Dielectric strength: 2000V AC @1 minute

(input to DC output to alarm output 1 to  
alarm output 2 to power to ground)

# FRONT PANEL CONFIGURATION

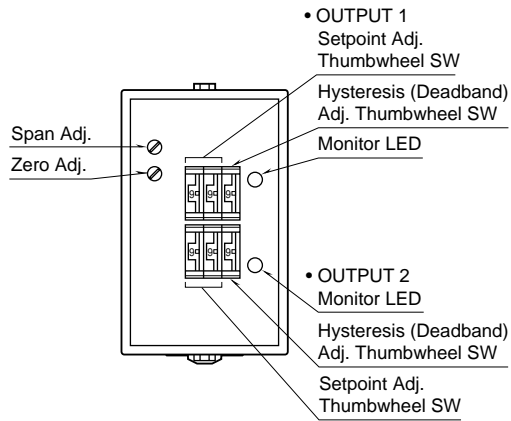

# SCHEMATIC CIRCUITRY & CONNECTION DIAGRAM

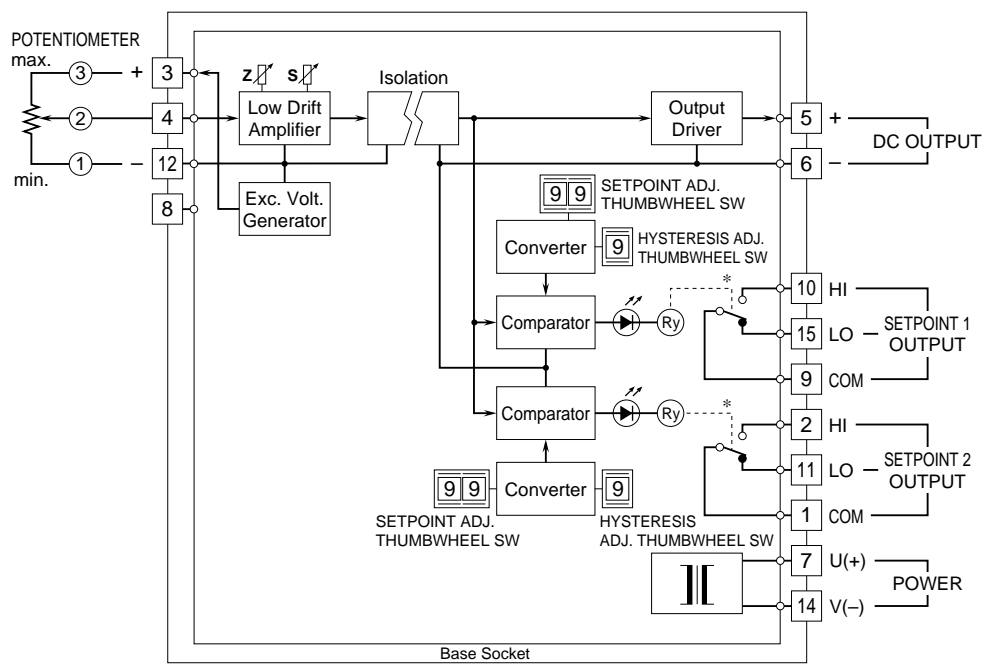

\*Relay status for output codes "1" & "4", at power OFF.

### Relay Protection

#### AC Powered

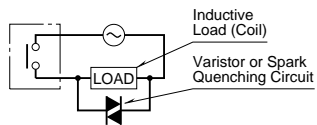

#### DC Powered

