

**Limit Alarms (with DC output) AE-UNIT**

**TWO-WIRE TRANSMITTER ALARM**  
(with square root extractor)

MODEL **AEDN**

**MODEL & SUFFIX CODE SELECTION**

AEDN-□□□□□□

**MODEL** \_\_\_\_\_

**INPUT** \_\_\_\_\_  
4 – 20mA DC

**DC OUTPUT** \_\_\_\_\_

**N** : None

<b>Current</b>	<b>Voltage</b>
<b>A</b> : 4 – 20mA DC	<b>1</b> : 0 – 10mV DC
<b>B</b> : 2 – 10mA DC	<b>2</b> : 0 – 100mV DC
<b>C</b> : 1 – 5mA DC	<b>3</b> : 0 – 1V DC
<b>D</b> : 0 – 20mA DC	<b>4</b> : 0 – 10V DC
<b>E</b> : 0 – 16mA DC	<b>5</b> : 0 – 5V DC
<b>F</b> : 0 – 10mA DC	<b>6</b> : 1 – 5V DC
<b>G</b> : 0 – 1mA DC	<b>4W</b> : -10 – +10V DC
<b>Z</b> : Specify current	<b>5W</b> : -5 – +5V DC
	<b>0</b> : Specify voltage

**SETPOINT 1 OUTPUT** \_\_\_\_\_

**1** : Hi (coil energized at alarm)  
**2** : Hi (coil de-energized at alarm)  
**3** : Lo (coil energized at alarm)  
**4** : Lo (coil de-energized at alarm)

**SETPOINT 2 OUTPUT** \_\_\_\_\_

**1** : Hi (coil energized at alarm)  
**2** : Hi (coil de-energized at alarm)  
**3** : Lo (coil energized at alarm)  
**4** : Lo (coil de-energized at alarm)

**ON DELAY TIME** \_\_\_\_\_

<b>0</b> : 0.5 seconds	<b>3</b> : 3 seconds
<b>1</b> : 1 second	<b>4</b> : 4 seconds
<b>2</b> : 2 seconds	

**POWER ON DELAY TIME** \_\_\_\_\_

<b>1</b> : 1 second	<b>4</b> : 4 seconds
<b>2</b> : 2 seconds	<b>5</b> : 5 seconds
<b>3</b> : 3 seconds	

**POWER INPUT** \_\_\_\_\_

<b>AC Power</b>		<b>DC Power</b>
<b>B</b> : 100V AC	<b>G</b> : 200V AC	<b>S</b> : 12V DC
<b>C</b> : 110V AC	<b>H</b> : 220V AC	<b>R</b> : 24V DC
<b>D</b> : 115V AC	<b>J</b> : 240V AC	<b>V</b> : 48V DC
<b>F</b> : 120V AC		<b>P</b> : 110V DC

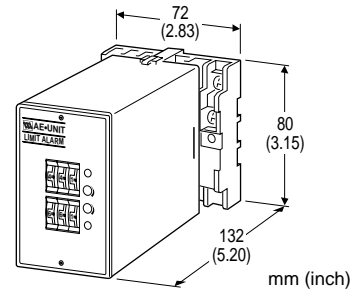

**Functions & Features**

- Powering a 4 – 20mA DC current loop
- Providing SPDT relay outputs at preset current levels
- Dual (Hi/Lo) trip
- Shortcircuit protection
- Square root extraction for DP transmitter
- Additional isolated DC output proportional to the input
- Energized or de-energized coil at a tripped condition selectable
- Thumbwheel switch adjustments
- Relays can be powered 110V DC

**ORDERING INFORMATION**

Specify code number and variables.

- **Code number** (e.g. AEDN-A2101-B)
- **Special DC output range** (For codes Z & 0)

**GENERAL SPECIFICATIONS**

**Construction:** plug-in

**Connection:** M3.5 screw terminals

**Housing material:** flame-resistant resin (black)

**Isolation:** input to DC output to relay output to power

**Zero/span adjustments:** ±5% (front)

**Setpoint adjustments:** thumbwheel switches (front); 0 – 99% independently; 1% increments

Remark: Setpoint is applied to the result of square root extraction. A setpoint below 10% output equals 0% due to the low-end cutout function.

**Hysteresis (deadband) adjustments:** thumbwheel switches (front); 0.5, 1 – 9% independently; 1% increments (SW position 0 = 0.5); [Lo SP + Hysteresis] ≤ 102

**Front LEDs:** red lights turn on when coils are energized.

**Low-end cutout:** approx. 1% (input)

**INPUT & OUTPUT****■SUPPLY OUTPUT****Output voltage:** 24 – 28V DC with no load**Current rating:** 22mA DC maximum**•Shortcircuit Protection****Current limited:** 30mA maximum**Protected time duration:** no limit**■INPUT:** 4 – 20mA DC; input resistor incorporated (2W)**Input resistance:** 250Ω**■DC OUTPUT****•DC Current:** 0 – 20mA DC**Minimum span:** 1mA**Zero suppression/elevation:** max. 1.5 times span**Load resistance:** output drive 7V maximum

Output	Load Resistance
4 – 20mA	: 350 (Ω maximum)
2 – 10mA	: 700
1 – 5mA	: 1400
0 – 20mA	: 350
0 – 16mA	: 430
0 – 10mA	: 700
0 – 1mA	: 7000

**•DC Voltage:** -10 – +12V DC**Minimum span:** 5mV**Zero suppression/elevation:** max. 1.5 times span**Load resistance:** output drive 1mA maximum; at  $\geq 0.5V$ 

Output	Load Resistance
0 – 10mV	: 10k (Ω minimum)
0 – 100mV	: 100k
0 – 1V	: 1000
0 – 10V	: 10k
0 – 5V	: 5000
1 – 5V	: 5000
-10 – +10V	: 10k
-5 – +5V	: 5000

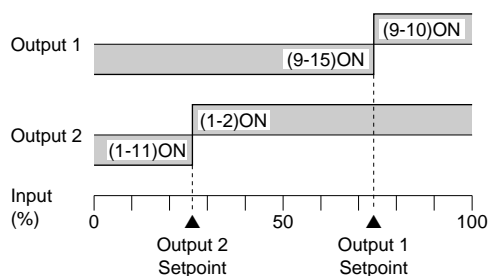
**■ALARM OUTPUT****Alarm Trip Operation** Terminal No. in parentheses**Trip Operation in Power Failure****•Output Code: 1 & 4:** Terminals 1 – 11, 9 – 15 turn ON**•Output Code: 2 & 3:** Terminals 1 – 2, 9 – 10 turn ON**•Relay Contact:** 120V AC @1A (cosφ=1)

240V AC @0.5A (cosφ=1)

30V DC @1A (resistive load)

electrical life  $5 \times 10^5$  cycles (rate 30/min.)**Maximum switching voltage:** 380V AC or 125V DC**Maximum switching power:** 100VA or 30W**Minimum load:** 5V DC @10mA**Mechanical life:**  $5 \times 10^7$  cycles

For maximum relay life with inductive loads, external protection is recommended.

**INSTALLATION****Power input****AC:** operational voltage range: rating  $\pm 10\%$ , 50/60  $\pm 2$  Hz, approx. 3VA**DC:** operational voltage range: rating  $\pm 10\%$ , or 85 – 150V for 110V rating; ripple 10% p-p max.; approx. 2W (80mA at 24V)**Operating temperature:** -5 to +55°C (23 to 131°F)**Operating humidity:** 30 to 90% RH (non-condensing)**Mounting:** surface or DIN rail**Dimensions:** W72×H80×D132 mm (2.83"×3.15"×5.20")  
See General Spec. Sheet Figure A-1.**Weight:** 450 g (0.99 lbs)**Terminal assignment:** See General Spec. Sheet Figure B-1.**PERFORMANCE in percentage of span****DC output****Accuracy:**  $\pm 0.2\%$  (input 1 – 100%)**Response time:**  $\leq 0.7$  seconds (0 – 90%)**Alarm output****Setpoint accuracy:**  $\pm 0.7\%$ **Hysteresis setpoint accuracy:**  $\pm 0.3\%$ **ON delay time accuracy:** rating  $\pm 20\%$  or 0.7 sec., whichever is greater.**Power ON delay time accuracy:** rating  $\pm 30\%$ **Trip point repeatability:**  $\pm 0.05\%$ **Temp. coefficient:**  $\pm 0.015\%/^{\circ}C$  ( $\pm 0.008\%/^{\circ}F$ )**Line voltage effect:**  $\pm 0.1\%$  over voltage range**Insulation resistance:**  $\geq 100M\Omega$  with 500V DC**Dielectric strength:** 2000V AC @1 minute

(input to DC output to alarm output 1 to alarm output 2 to power to ground)

# FRONT PANEL CONFIGURATION

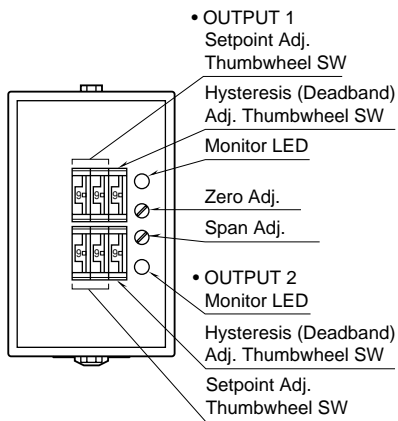

# SCHEMATIC CIRCUITRY & CONNECTION DIAGRAM

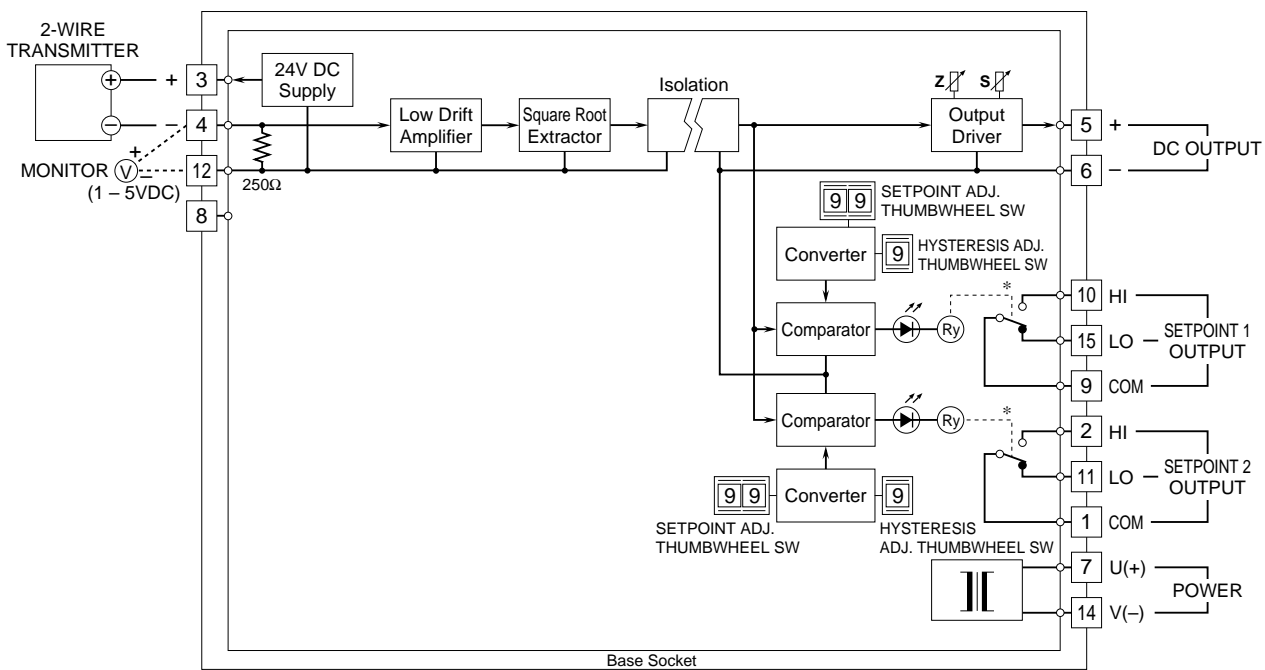

\*Relay status for output codes "1" & "4", at power OFF.

### Relay Protection

