

Limit Alarms (with DC output) AE-UNIT

AC ALARM

MODEL AEAC

MODEL & SUFFIX CODE SELECTION

AEAC-□□□□□□□□

MODEL _____									
INPUT _____									
Current		Voltage							
AA : 0 – 10mA AC		A1 : 0 – 100mV AC							
AB : 0 – 50mA AC		A2 : 0 – 500mV AC							
AC : 0 – 100mA AC		A3 : 0 – 1V AC							
AD : 0 – 500mA AC		A4 : 0 – 5V AC							
AZ : Specify current*		A5 : 0 – 10V AC							
		A6 : 0 – 120V AC							
		A7 : 0 – 150V AC							
		A8 : Specify voltage*							
*0% input must be 0mA or 0V.									
DC OUTPUT _____									
N : None									
Current		Voltage							
A : 4 – 20mA DC		1 : 0 – 10mV DC							
B : 2 – 10mA DC		2 : 0 – 100mV DC							
C : 1 – 5mA DC		3 : 0 – 1V DC							
D : 0 – 20mA DC		4 : 0 – 10V DC							
E : 0 – 16mA DC		5 : 0 – 5V DC							
F : 0 – 10mA DC		6 : 1 – 5V DC							
G : 0 – 1mA DC		4W : -10 – +10V DC							
Z : Specify current		5W : -5 – +5V DC							
		0 : Specify voltage							
SETPOINT 1 OUTPUT _____									
1 : Hi (coil energized at alarm)									
2 : Hi (coil de-energized at alarm)									
3 : Lo (coil energized at alarm)									
4 : Lo (coil de-energized at alarm)									
SETPOINT 2 OUTPUT _____									
1 : Hi (coil energized at alarm)									
2 : Hi (coil de-energized at alarm)									
3 : Lo (coil energized at alarm)									
4 : Lo (coil de-energized at alarm)									
ON DELAY TIME _____									
0 : 0.5 seconds		3 : 3 seconds							
1 : 1 second		4 : 4 seconds							
2 : 2 seconds									
POWER ON DELAY TIME _____									
1 : 1 second		4 : 4 seconds							
2 : 2 seconds		5 : 5 seconds							
3 : 3 seconds									
POWER INPUT _____									
AC Power		DC Power							
B : 100V AC		G : 200V AC		S : 12V DC					
C : 110V AC		H : 220V AC		R : 24V DC					
D : 115V AC		J : 240V AC		V : 48V DC					
F : 120V AC		P : 110V DC							

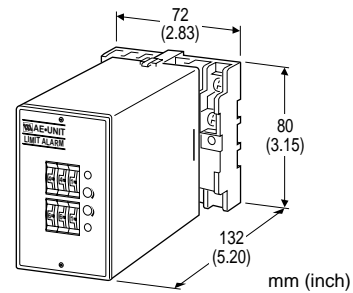

Functions & Features

- Providing SPDT relay outputs at preset AC current/voltage levels
- Dual (Hi/Lo) trip
- Additional isolated DC output proportional to the input
- True RMS sensing
- Energized or de-energized coil at a tripped condition selectable
- Thumbwheel switch adjustments
- Relays can be powered 110V DC

ORDERING INFORMATION

Specify code number and variables.
 • **Code number** (e.g. AEAC-A6A2101-B)
 • **Special input and DC output ranges**
 (For codes AZ, A8, Z & 0)

GENERAL SPECIFICATIONS

- Construction:** plug-in
- Connection:** M3.5 screw terminals
- Housing material:** flame-resistant resin (black)
- Isolation:** input to DC output to relay output to power
- Input waveform:** up to 15% of 3rd harmonic content
- Zero/span adjustments:** ±5% (front)
- Setpoint adjustments:** thumbwheel switches (front); 0 – 99% independently; 1% increments
- Hysteresis (deadband) adjustments:** thumbwheel switches (front); 0.5, 1 – 9% independently; 1% increments (SW position 0 = 0.5); [Lo SP + Hysteresis] ≤ 102
- Front LEDs:** red lights turn on when coils are energized.

INPUT & OUTPUT

INPUT

Frequency: 40 Hz min., 1 kHz max. with 100% input

AC Current: 0 – 1A AC; input resistor (2W) incorporated

Minimum span: 1mA

Input resistance

Input	Input Resistance
1mA	: 1k (Ω)
≤2mA	: 500
≤5mA	: 200
≤10mA	: 100
≤20mA	: 50
≤50mA	: 20
≤100mA	: 10
≤500mA	: 1
≤1A	: 0.5

AC Voltage: 0 – 250V AC

Minimum span: 50mV

Input resistance: 100kΩ minimum

DC OUTPUT

DC Current: 0 – 20mA DC

Minimum span: 1mA

Zero suppression/elevation: max. 1.5 times span

Load resistance: output drive 7V maximum

Output	Load Resistance
4 – 20mA	: 350 (Ω maximum)
2 – 10mA	: 700
1 – 5mA	: 1400
0 – 20mA	: 350
0 – 16mA	: 430
0 – 10mA	: 700
0 – 1mA	: 7000

DC Voltage: -10 – +12V DC

Minimum span: 5mV

Zero suppression/elevation: max. 1.5 times span

Load resistance: output drive 1mA maximum; at ≥0.5V

Output	Load Resistance
0 – 10mV	: 10k (Ω minimum)
0 – 100mV	: 100k
0 – 1V	: 1000
0 – 10V	: 10k
0 – 5V	: 5000
1 – 5V	: 5000
-10 – +10V	: 10k
-5 – +5V	: 5000

ALARM OUTPUT

Alarm Trip Operation Terminal No. in parentheses

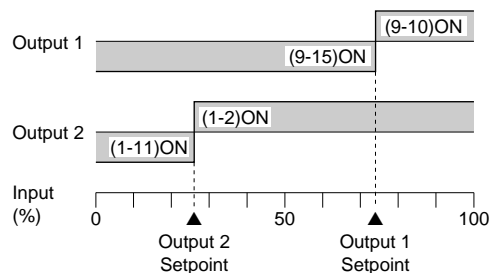

Trip Operation in Power Failure

- **Output Code: 1 & 4:** Terminals 1 – 11, 9 – 15 turn ON
- **Output Code: 2 & 3:** Terminals 1 – 2, 9 – 10 turn ON

- **Relay Contact:** 120V AC @1A (cosφ=1)
240V AC @0.5A (cosφ=1)
30V DC @1A (resistive load)
electrical life 5 × 10⁵ cycles (rate 30/min.)

Maximum switching voltage: 380V AC or 125V DC

Maximum switching power: 100VA or 30W

Minimum load: 5V DC @10mA

Mechanical life: 5 × 10⁷ cycles

For maximum relay life with inductive loads, external protection is recommended.

INSTALLATION

Power input

AC: operational voltage range: rating ±10%, 50/60 ±2 Hz, approx. 3VA

DC: operational voltage range: rating ±10%, or 85 – 150V for 110V rating; ripple 10% p-p max.; approx. 2W (80mA at 24V)

Operating temperature: -5 to +55°C (23 to 131°F)

Operating humidity: 30 to 90% RH (non-condensing)

Mounting: surface or DIN rail

Dimensions: W72×H80×D132 mm (2.83"×3.15"×5.20")
See General Spec. Sheet Figure A-1.

Weight: 450 g (0.99 lbs)

Terminal assignment: See General Spec. Sheet Figure B-1.

PERFORMANCE in percentage of span

DC output

Accuracy: $\pm 0.4\%$

Response time: ≤ 0.7 seconds (0 – 90%)

Alarm output

Setpoint accuracy: $\pm 0.9\%$

Hysteresis setpoint accuracy: $\pm 0.3\%$

ON delay time accuracy: rating $\pm 20\%$ or 0.7 sec.,
whichever is greater.

Power ON delay time accuracy: rating $\pm 30\%$

Trip point repeatability: $\pm 0.05\%$

Temp. coefficient: $\pm 0.015\%/^{\circ}\text{C}$ ($\pm 0.008\%/^{\circ}\text{F}$)

Line voltage effect: $\pm 0.1\%$ over voltage range

Insulation resistance: $\geq 100\text{M}\Omega$ with 500V DC

Dielectric strength: 2000V AC @1 minute

(input to DC output to alarm output 1 to
alarm output 2 to power to ground)

FRONT PANEL CONFIGURATION

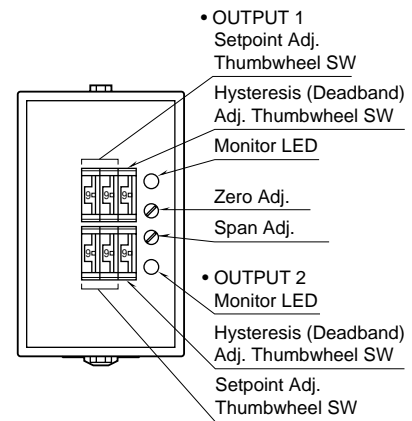

SCHEMATIC CIRCUITRY & CONNECTION DIAGRAM

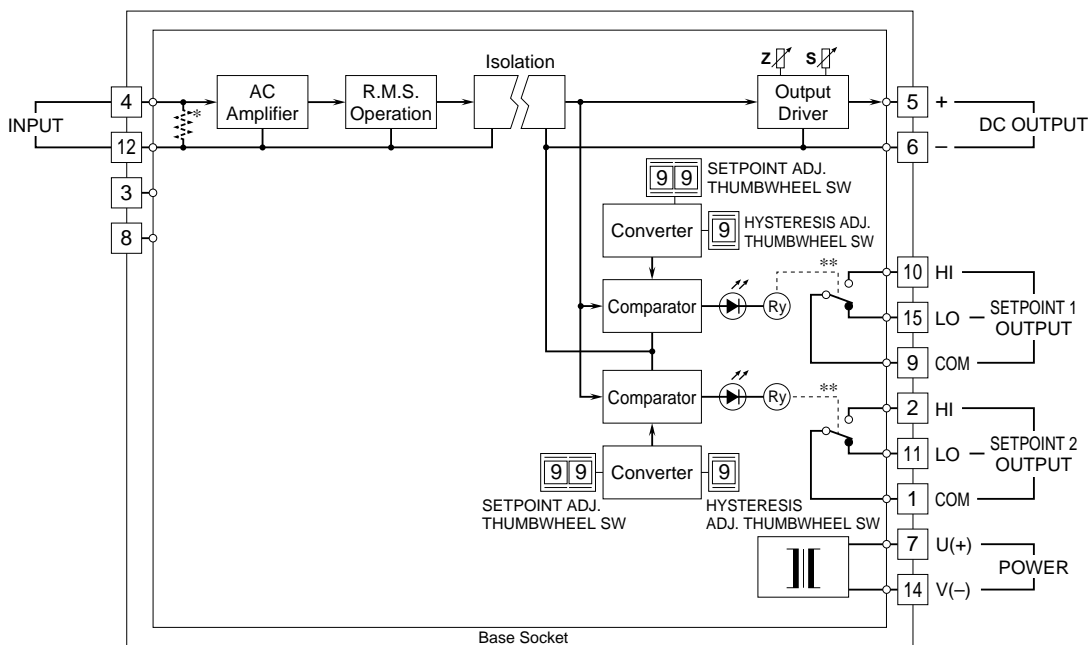

* Input resistor incorporated for current input.

**Relay status for output codes "1" & "4", at power OFF.

Relay Protection

AC Powered

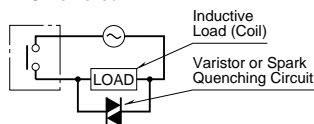

DC Powered

