

Lightning Surge Protectors for Electronics Equipment M-RESTER

LIGHTNING SURGE PROTECTOR FOR PROFIBUS-PA

MODEL **MDP-PA**

MODEL & SUFFIX CODE SELECTION

MODEL _____ **MDP-PA**

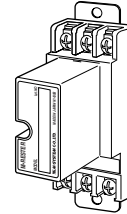

Functions & Features

- Designed specifically for PROFIBUS-PA network
- No interruption of transmission signal by unplugging the head element module

APPLICABLE NETWORK

PROFIBUS-PA, Foundation Fieldbus and other networks complied with IEC 61158-2

Note 1. This unit is not approved for classified locations.
 Note 2. Power supply to the bus must be limited to 500mA or less.

GENERAL SPECIFICATIONS

- Construction:** Plug-in
- Connection:** M4 screw terminals
(nickel-plated steel; torque 0.8 N·m)
- Housing material:** Flame-resistant resin (black)

INSTALLATION

- Operating temperature:** -5 to +55°C (23 to 131°F)
- Operating humidity:** 30 to 90% RH (non-condensing)
- Mounting:** Surface; DIN Rail Mounting Adaptor (model: A-33) separately available for DIN rail mounting.
- Dimensions:** W31.5×H100×D80 mm (1.24"×3.94"×3.15")
- Weight:** 100 g (0.22 lbs)

PERFORMANCE

	BETWEEN LINES	LINE TO TO GND	SHIELD TO GND
Discharge voltage	±30V min.	±160V min.	±160V min.
Max. surge voltage*	±60V max.	±600V max.	±600V max.
Leakage current	≤5μA @±27V	≤5μA @±160V	≤5μA @±160V
Response time	≤4 nsec.	≤20 nsec.	≤20 nsec.
Capacitance (approx.)	1500 pF @10 kHz	100 pF @10 kHz	100 pF @10 kHz
Discharge current	5000A (8 / 20 μsec.)		
Max. load current	500mA		
Internal series resist.	approx. 3.3Ω including return		
Max. line voltage	±27V		

*The maximum voltage that could pass through M-RESTER. Protected equipment must be able to withstand this voltage for a very short time period.

SCHEMATIC CIRCUITRY

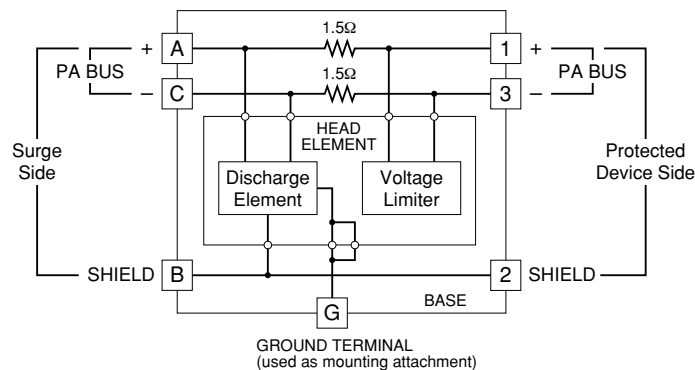

TERMINAL CONNECTIONS

CONNECTION DIAGRAM

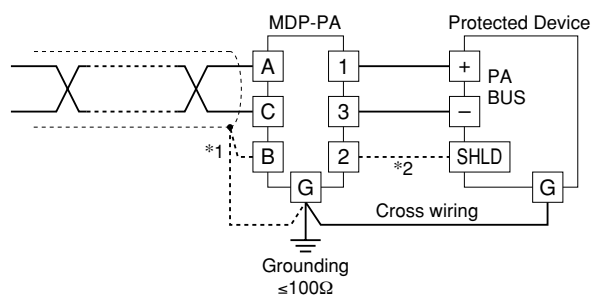

- *1. Cross wire to the surge protector's [G] terminal when grounding the shield wire. If the shield wire is not to be grounded, connect it to [B] terminal.
- *2. Follow instructions provided with the protected device whether [2] terminal should be connected or not. However, if the shield terminal of the protected device is not isolated from PA BUS, DO NOT connect [2] terminal to the protected device.

NETWORK CONFIGURATION

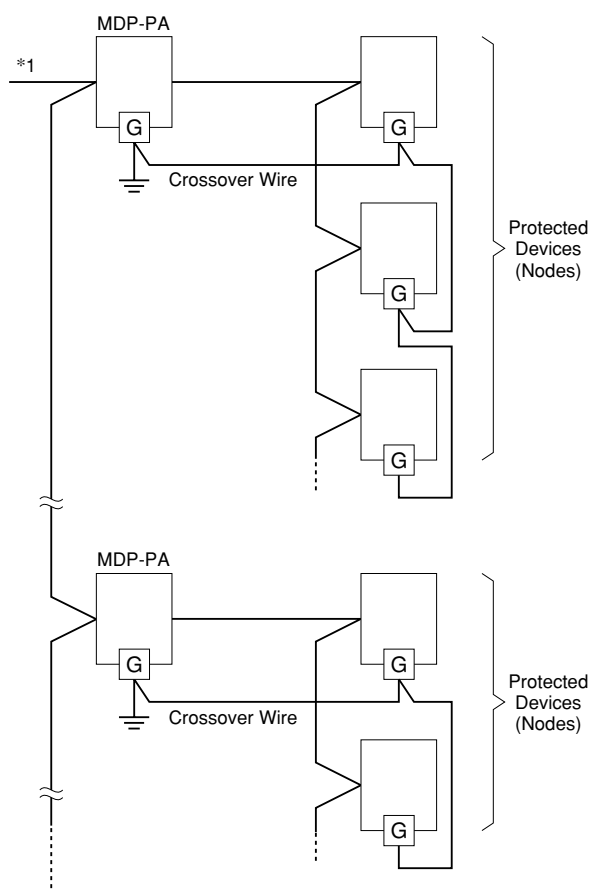

- *1. Fieldbus devices complying with IEC 61158-2 operate by a supply voltage between 9V and 32V DC. Take the MDP-PA's internal series resistance into consideration when determining the cable distance if there is a large current flow on the bus line.

When the distance between nodes are relatively long (e.g. grouped and separated by cabinets), install the MDP-PA by each group of devices. Insert the MDP-PA at the surge side of the network. For detailed information on the network, refer to that provided by PROFIBUS International or Fieldbus Foundation.

MOUNTING REQUIREMENTS (unit: mm)

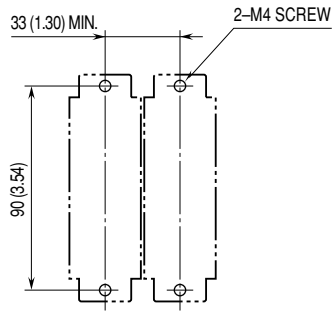

GROUNDING

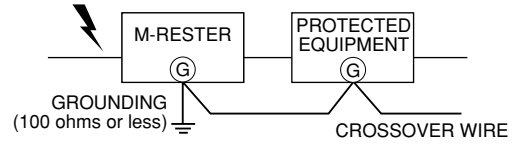

A crossover wire between M-RESTER ground and ground or metallic housing of equipment is required for protection. If the protected equipment has no ground terminal, ground the M-RESTER only.

EXTERNAL DIMENSIONS & TERMINAL ASSIGNMENT (unit: mm)

