

Lightning Surge Protectors for Electronics Equipment M-RESTER

LIGHTNING SURGE PROTECTOR FOR POWER SUPPLY USE
(DC power use)

MODEL **MDH**

MODEL & SUFFIX CODE SELECTION

MODEL _____ MDH-□
 LINE VOLTAGE _____
 12 : 12V DC
 24 : 24V DC
 48 : 48V DC

ORDERING INFORMATION

Specify code number. (e.g. MDH-24)

GENERAL SPECIFICATIONS

Construction: plug-in
Connection: M3.5 screw terminals
 (chromated steel; torque 0.8 N·m)
Housing material: flame-resistant resin (black)
Alarm indicator: red LEDs turn off with an abnormality

INSTALLATION

Operating temperature: -5 to +55°C (23 to 131°F)
Operating humidity: 30 to 90% RH (non-condensing)
Mounting: surface or DIN rail
Dimensions: W50×H80×D123 mm (1.97"×3.15"×4.84")
Weight: 250 g (0.55 lbs)

PERFORMANCE

Discharge voltage
 Between lines: 24V min. (MDH-12)
 50V min. (MDH-24)
 88V min. (MDH-48)
 Line to ground: ±380V min.
Maximum surge voltage*
 Between lines: 70V max. (MDH-12)
 140V max. (MDH-24)
 210V max. (MDH-48)
 Line to ground: ±700V max.
 *The maximum voltage that could pass through M-RESTER. Protected equipment must be able to withstand this voltage for very short time period.
Leakage current
 Between lines**: ≤15mA at 15V DC (MDH-12)
 ≤15mA at 30V DC (MDH-24)
 ≤20mA at 70V DC (MDH-48)
 **including the current consumed by LEDs
 Line to ground: ≤1mA at ±380V DC

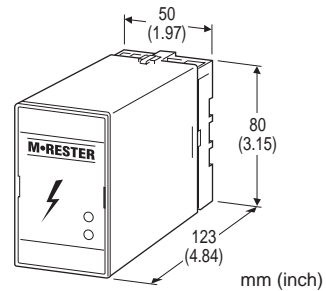

Functions & Features

- Designed specifically for DC power supplies up to 5 amps
- Absorbing surges only without affecting instrumentation signal
- Indicator LED for surge absorber failure
- Fuse provided for detaching the discharge elements

Typical Applications

- Power supplies for control equipment
- Relays, level switches, proximity switches
- Protecting the output side of a switching regulator type power supply

Response time: ≤0.1 microseconds

Discharge current capacity: 2000A (8 / 20 μsec.)

Maximum load current: 5A

Internal voltage drop: ≤1V

Max. continuous operating voltage:

15V DC (MDH-12)

30V DC (MDH-24)

70V DC (MDH-48)

FRONT PANEL CONFIGURATION

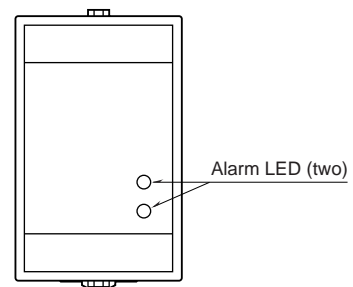

SCHEMATIC CIRCUITRY

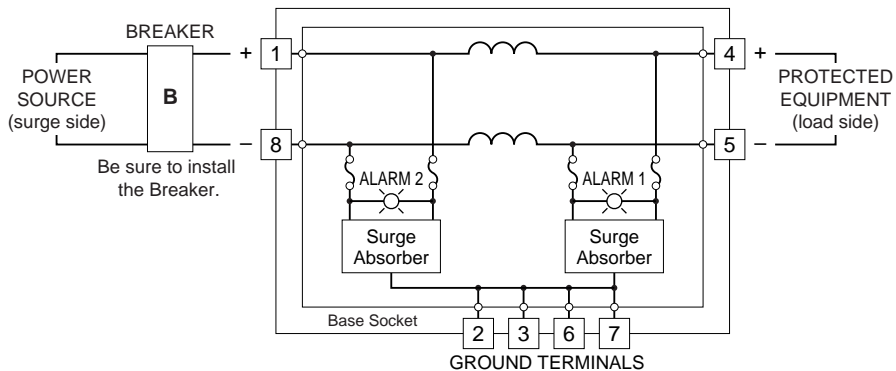

CONNECTION DIAGRAM

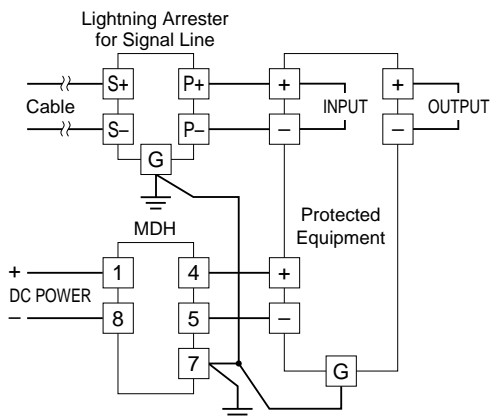

Ground one of the terminals 2, 3, 6 and 7.

GROUNDING

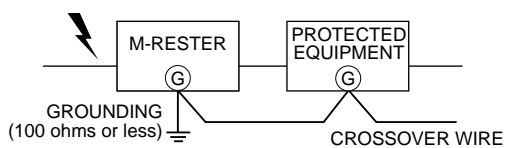

A crossover wire between M-RESTER ground and ground or metallic housing of equipment is required for protection. If the protected equipment has no ground terminal, ground the M-RESTER only.

EXTERNAL DIMENSIONS & TERMINAL ASSIGNMENT mm (inch)

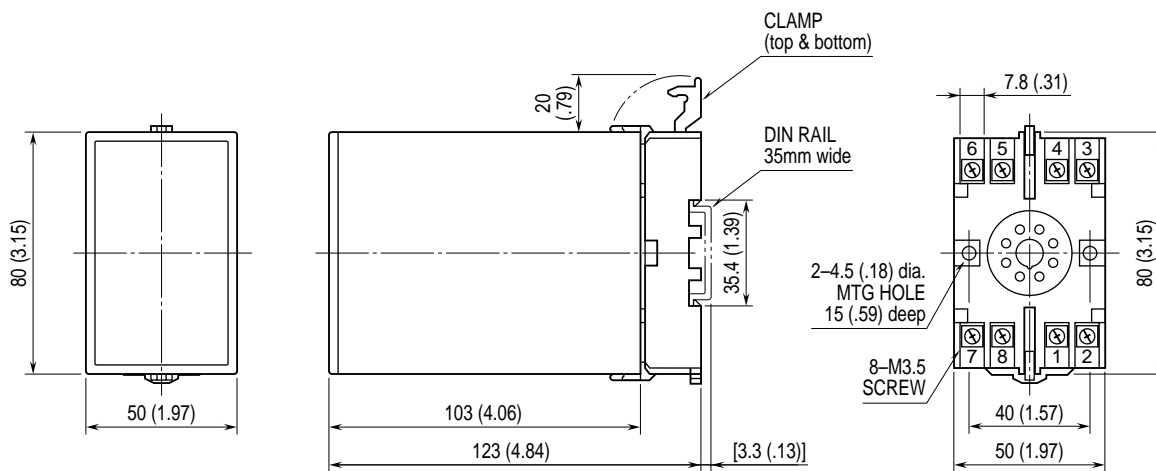

•When mounting, no extra space is needed between units.