

Lightning Surge Protectors for Electronics Equipment *M-RESTER*

LIGHTNING SURGE PROTECTOR FOR STANDARD SIGNAL LINE (ultra-slim)

MODEL **MD7ST**

MODEL & SUFFIX CODE SELECTION

MODEL _____ MD7ST-□□□□

NOMINAL VOLTAGE _____

24: 24V DC
60: 60V DC

SHIELD TERMINAL (line / earth) _____

FF : Floating / Floating (standard)
FG : Floating / Grounding
GF : Grounding / Floating
GG : Grounding / Grounding

LOOP DISCONNECT FUSE _____

0 : Without
1 : With

SAFETY APPROVAL _____

0 : None
1 : FM intrinsically safe (future plan)
2 : CENELEC intrinsically safe (ATEX) (future plan)

ORDERING INFORMATION

Specify code number. (e.g. MD7ST-24FF00)

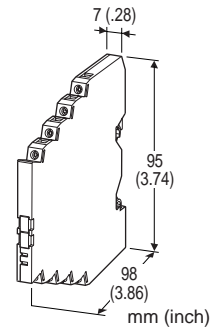

Functions & Features

- High discharge current capacity 20 kA (8 / 20 μs), 1 kA (10 / 350 μs)
- Ultra-thin 7-mm-wide module can be mounted in high density
- Excellent protection employing multi-stage SPD circuits
- DIN rail mounting and grounding
- Shield terminal provided

GENERAL SPECIFICATIONS

Ingress protection: IP 20

Connection: Euro terminal block (torque 0.3 N·m)

Applicable wire size: 0.2 – 2.5 mm²

Housing material: Flame-resistant resin (black)

Grounding: DIN Rail

Loop disconnect fuse: Separates the protected device from the power source when the former fails in the shortcircuit mode.
Current rating 250mA

INSTALLATION

Operating temperature: -25 to +85°C (-13 to +185°F)

Operating humidity: 30 to 90% RH (non-condensing)

Mounting: DIN Rail (TH35-7.5, 1-mm-thick)

Oxide coating of an aluminum rail may lower the electric conductivity between this module and the ground. Use a steel or copper rail.

Dimensions: W7×H98×D95 mm (0.28"×3.86"×3.74")

Weight: 70 g (2.5 oz)

PERFORMANCE

MODEL NO.	NOMINAL VOLTAGE SHLD TERMINAL	MD7ST-24				MD7ST-60			
		FF	FG	GF	GG	FF	FG	GF	GG
Max. continuous operating voltage (U _c)	Line to Line	30V				70V			
	Ling to Earth	±160V			30V	±160V			70V
	Line to SHLD	±160V		30V		±160V		70V	
	SHLD to Earth	±160V	short	±160V	short	±160V	short	±160V	short
Voltage protection Level (Up) @4kV (1.2 / 50 μs)	Line to Line	60V max.				115V max.			
	Ling to Earth	±800V max.			±60V max.	±800V max.			±115V max.
	Line to SHLD	±1200V max.	±800V max.	±60V max.		±1200V max.	±800V max.	±115V max.	
	SHLD to Earth	±800V max.	short	±800V max.	short	±800V max.	short	±800V max.	short
Leakage current @U _c	Line to Line	≤5μA				≤5μA			
	Other sections	≤5μA				≤5μA			
Response time	Line to Line	≤4 nsec.				≤4 nsec.			
	Other sections	≤20 nsec.				≤20 nsec.			
Max. discharge current (I _{max})	20kA (8 / 20 μs), 1.0kA (10 / 350 μs)								
Nominal current (I _N)	250mA								
Internal series resistance	Without fuse	4.7Ω ±10% per line				10Ω ±10% per line			
	With fuse	7.5Ω ±10% per line				12.5Ω ±10% per line			

STANDARDS & APPROVALS

CE conformity: EMC Directive (89/336/EEC)

EMI EN61000-6-4

EMS EN61000-6-2

Surge protection: IEC 61643-21

(Categories C1, C2, D1)

EXTERNAL DIMENSIONS & TERMINAL ASSIGNMENT (unit: mm)

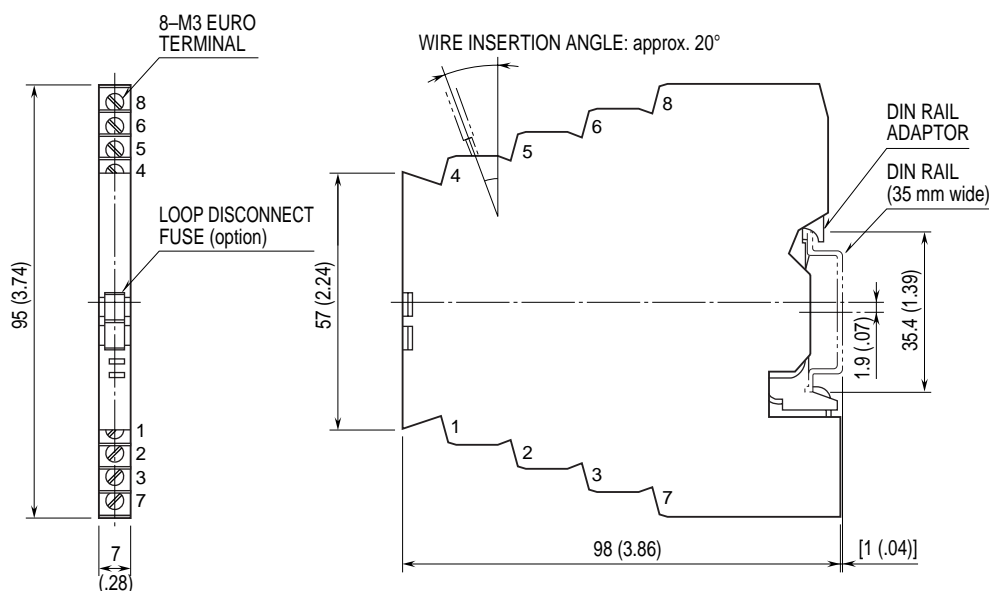

Specifications subject to change without notice.

SCHEMATIC CIRCUITRY

SHIELD TERMINAL	MODEL NO.	SCHEMATIC CIRCUITRY	APPLICATIONS
<ul style="list-style-type: none"> Line to SHLD: Floating Earth to SHLD: Floating 	<ul style="list-style-type: none"> MD7ST-xFF0x (No fuse option) MD7ST-xFF1x (Fuse option) 		<ul style="list-style-type: none"> Standard type To protect a device having isolation between Signal and Earth. When SHLD should be floating against the earth. (single-end grounding)
<ul style="list-style-type: none"> Line to SHLD: Floating Earth to SHLD: Grounding 	<ul style="list-style-type: none"> MD7ST-xFG0x (No fuse option) MD7ST-xFG1x (Fuse option) 		<ul style="list-style-type: none"> To protect a device having isolation between Signal and Earth. When SHLD should be grounded. (single- or both-end grounding)
<ul style="list-style-type: none"> Line to SHLD: Grounding Earth to SHLD: Floating 	<ul style="list-style-type: none"> MD7ST-xGF0x (No fuse option) MD7ST-xGF1x (Fuse option) 		<ul style="list-style-type: none"> To protect a device having isolation between Signal and Earth. When SHLD wire should be connected to SG terminal of the protected device. (SHLD is not grounded to the earth.)
<ul style="list-style-type: none"> Line to SHLD: Grounding Earth to SHLD: Grounding 	<ul style="list-style-type: none"> MD7ST-xGG0x (No fuse option) MD7ST-xGG1x (Fuse option) 		<ul style="list-style-type: none"> To protect a device which does not have a good dielectric strength between Signal and Earth.

Sections enclosed with broken line may differ depending upon the models.

SELECTING SHIELD TERMINAL TYPE

- The surge protector has a dedicated shield terminal effective for easy shield wiring and surge protection.
- Review the shield method (grounding, non-grounding, connecting to SG, etc.) required by the protected device or system.
- There is no electrical effect to the shield by installing the surge protector, but an appropriate shield terminal type must be selected to suit user applications.
- Refer to the flow chart below to choose.

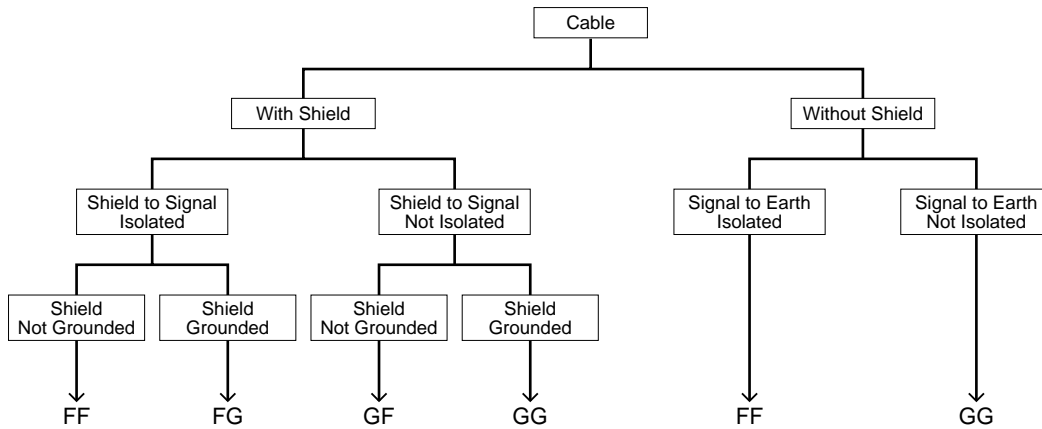

SELECTING LOOP DISCONNECT FUSE

- Choose 'Loop disconnect fuse' type when multiple transmitters are connected to single power bus.
- Loop disconnect fuse is used to separate a loop from the power bus when it fails in shortcircuit mode.

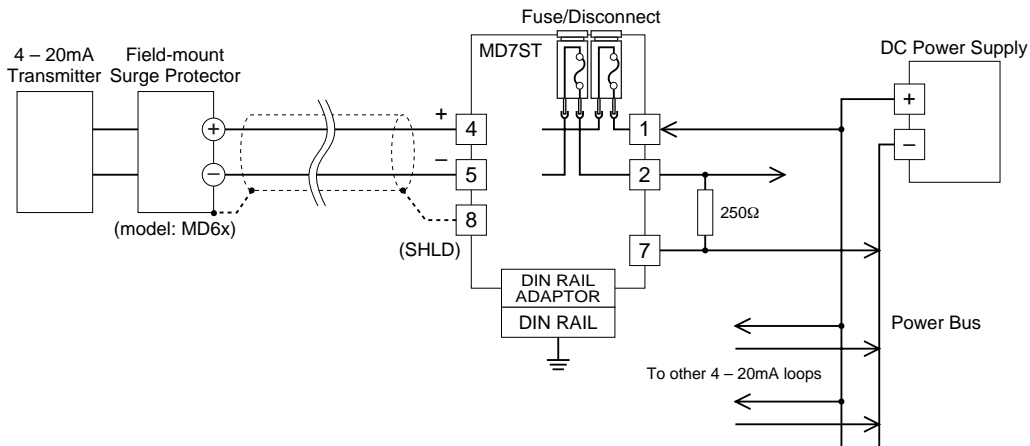

CONNECTION DIAGRAM

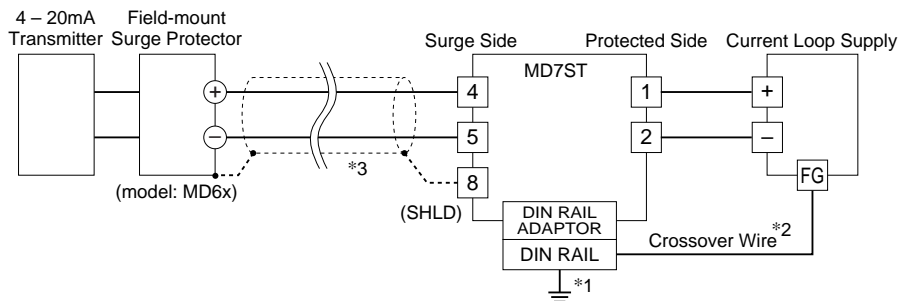

- *1. Be sure to ground the DIN rail. Recommended grounding resistance $\leq 100\Omega$
- *2. Cross-wire between the DIN rail and the metal housing of the protected device to equalize the earth potential. Ground only the surge protector when the protected device has no ground terminal.
- *3. Shield wiring method is an example. Proceed according to the system requirements.