

Lightning Surge Protectors for Electronics Equipment M-RESTER

LIGHTNING SURGE PROTECTOR FOR STANDARD SIGNAL LINE & PULSE USE (conduit mount, weather-proof)

MODEL **MD6T-24**
MD6T-65

MODEL & SUFFIX CODE SELECTION

MD6T-24-□□□
MD6T-65

MODEL _____

MD6T-24: 24V DC line voltage

MD6T-65: 65V DC line voltage

SAFETY APPROVAL _____

0 : None

1 : FM intrinsically safe *1

2 : CENELEC intrinsically safe (ATEX) *1

4 : CENELEC flameproof (ATEX)

5 : FM nonincendive *1

WIRING CONDUIT _____

0 : G 1/2 *2

1 : 1/2 NPT

2 : M20 × 1.5

BODY MATERIAL _____

B : Brass

S : Stainless steel

*1 : Not selectable for 65V DC line voltage.

*2 : Not selectable for CENELEC flameproof approval.

ORDERING INFORMATION

Specify code number. For the safety approval codes 2 and 4, specify the product's destination country using Ordering Information Sheet (No. ESU-8284).

• **Code number** (e.g. MD6T-24-00B)

GENERAL SPECIFICATIONS

Environmental protection: IP65

Wiring conduit: See 'Model & Suffix Code.'

Electrical connection

Cable side: Terminal block (leadwire diameter: 0.14 – 1.5 mm² for both stranded and single-core wires; or AWG26 – 16)

Equipment side: Leadwires (leadwire diameter AWG20 for grounding; AWG22 for the protected equipment)

Body material: Nickel-plated brass or stainless steel 316

INSTALLATION

Operating temperature: -40 to +85°C (-40 to +185°F)

(See Safety Parameters for use in a hazardous location.)

Mounting: Screwed into an electrical conduit of outdoor enclosures

Dimensions: See 'External Dimensions.'

Weight: Approx. 500 g (1.10 lbs)

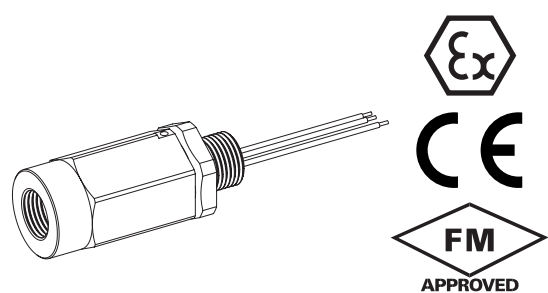

Functions & Features

- Designed specifically for 4 – 20mA DC and pulse signal line including both 4-wire and 2-wire transmitters
- Direct mount in a wiring conduit of outdoor enclosures
- Absorbing surges only without affecting instrumentation signal

PERFORMANCE

	BETWEEN LINES		LINE TO GND
	MD6T-24	MD6T-65	
Discharge voltage (peak voltage)	30V min.	70V min.	±160V min.
Max. surge voltage*	40V max.	100V max.	±650V max.
Leakage current	≤5μA @30V DC	≤5μA @70V DC	≤5μA @±160V DC
Max. line voltage	30V DC	70V DC	—
[] safety approval	[28V]	[66V]	—
Response time	≤4 nsec.	≤4 nsec.	≤20 nsec.
Capacitance	≤2500 pF @1kHz	≤2500 pF @1kHz	≤100 pF @1kHz
Discharge current	10000A (8 / 20 μsec.)		
Max. load current	100mA		
Internal series resist.	approx. 22Ω including return		

*The maximum voltage that could pass through M-RESTER. Protected equipment must be able to withstand this voltage for a very short time period.

CABLE GLAND

The packing of the cable gland must be separate from the body. Choose an appropriate one for the environment in which the surge protector is used.

STANDARDS & APPROVAL

CE conformity: ATEX Directive (94/9/EC)
 EEx ia EN50020
 Category 1G EN50284
 Ex d EN60079-1
 EMC Directive (89/336/EEC)
 EMI EN61000-6-4
 EMS EN61000-6-2

Safety approval

FM: Intrinsically safe
 Class I, Div. 1, Groups A, B, C and D
 Class II, Div. 1, Groups E, F and G
 Class III, Div. 1
 Class I, Zone 0, AEx ia IIC
 T5 and T6
 (Class 3610)

FM: Nonincendive
 Class I, Div. 2, Groups A, B, C, and D
 Class II, Div. 2, Groups E, F and G
 Class III, Div. 1
 T6
 (Class 3611)

CENELEC: Intrinsically safe (ATEX)
 Ⓢ II 1G, EEx ia IIC; T5 and T6
 (EN50020, EN50284)

CENELEC: Flameproof (ATEX)
 Ⓢ II 2G, Ex d IIC; T5 and T6
 (EN60079-1)

SAFETY PARAMETERS

Operating temperature:
 T5 -40 to +80°C
 T6 -40 to +70°C
 -40 to +75°C for CENELEC (ATEX) flameproof
 -40 to +80°C for FM nonincendive

Ex-data: U_i (Vmax) 30V*
 I_i (Imax) 100mA*
 P_i 750mW
 C_i 2.5 nF
 L_i 0 mH

* 'Any' for CENELEC (ATEX) intrinsically safe approval

SCHEMATIC CIRCUITRY

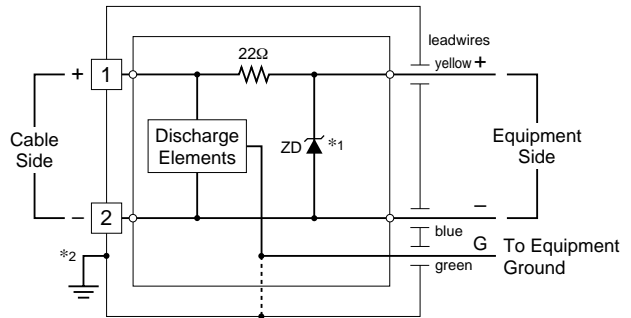

*1. The zener diode has polarity. Zero-cross signal cannot be connected.
 *2. Use only when the signal line require functional grounding.
 This is NOT for surge protection.

CONNECTION DIAGRAM & GROUNDING

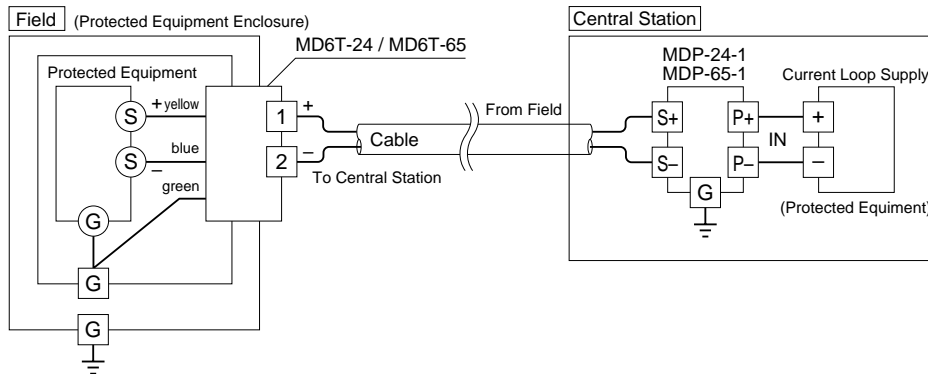

Connect the MD6T's green leadwire to the ground terminal inside the protected equipment enclosure to ground through the enclosure's outside ground terminal.
 If the enclosure does not have an inside ground terminal, connect the green leadwire directly to the outside ground wire pulled inside the enclosure. Keep the ground wire as short as possible.

EXTERNAL DIMENSIONS mm (inch)

■ WITHOUT SAFETY APPROVAL

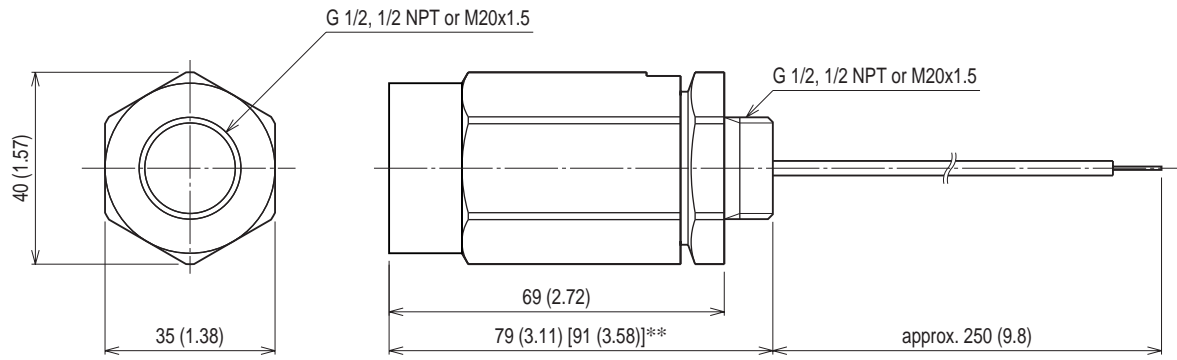

■ WITH SAFETY APPROVAL

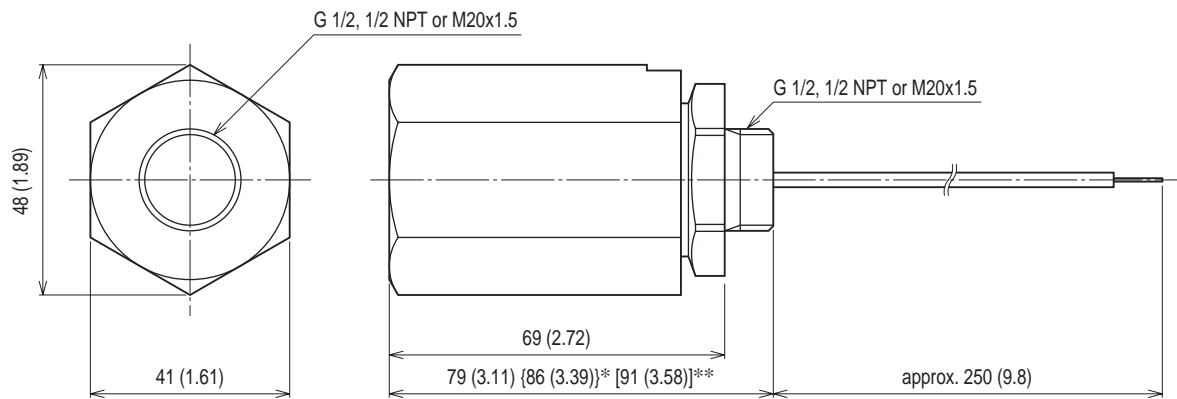

* { } for M20x1.5 with CENECEC (ATEX) flameproof approval
 **[] for 1/2 NPT