

Lightning Surge Protectors for Electronics Equipment M-RESTER

LIGHTNING SURGE PROTECTOR FOR STANDARD SIGNAL LINE & PULSE USE (conduit mount, weather-proof)

MODEL **MD6P-24**
MD6P-65

MODEL & SUFFIX CODE SELECTION

MD6P-24-□□□
MD6P-65

MODEL _____

MD6P-24 : 24V DC line voltage

MD6P-65 : 65V DC line voltage

SAFETY APPROVAL _____

0 : None

1 : FM intrinsically safe *1

2 : CENELEC intrinsically safe (ATEX) *1

3 : FM explosion-proof

4 : CENELEC flameproof (ATEX)

5 : FM nonincendive *1

WIRING CONDUIT *2 _____

0 : G 1/2

1 : 1/2 NPT

2 : M20 × 1.5

BODY MATERIAL _____

B : Brass

S : Stainless steel

*1 : Not selectable for 65V DC line voltage.

*2 : Confirm selectable combinations of approval and wiring conduit types in the table below.

SELECTABLE WIRING CONDUITS SPECIFIC TO EACH APPROVAL

'N' marked combinations are not selectable.

WIRING CONDUIT	APPROVAL					
	0	1	2	3	4	5
0	Y	Y	Y	N	N	Y
1	Y	Y	Y	Y	Y	Y
2	Y	Y	Y	N	Y	Y

ORDERING INFORMATION

Specify code number. For the safety approval codes 2 and 4, specify the product's destination country using Ordering Information Sheet (No. ESU-8284).

• **Code number** (e.g. MD6P-24-00B)

GENERAL SPECIFICATIONS

Environmental protection: IP65

Wiring conduit: See 'Model & Suffix Code.'

Electrical connection: Leadwires

Leadwire diameters

Cable side & grounding: AWG20

Protected equipment side: AWG22

Body material: Nickel-plated brass or stainless steel

316

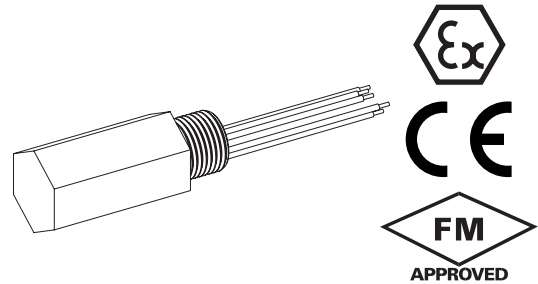

Functions & Features

- Designed specifically for 4 – 20mA DC and pulse signal line including both 4-wire and 2-wire transmitters
- Direct mount in a wiring conduit of outdoor enclosures
- Absorbing surges only without affecting instrumentation signal

INSTALLATION

Operating temperature: -40 to +85°C (-40 to +185°F)
(See Safety Parameters for use in a hazardous location.)

Mounting: Screwed into an electrical conduit of outdoor enclosures

Dimensions: See 'External Dimensions.'

Weight: Approx. 300 g (0.66 lbs)

PERFORMANCE

	BETWEEN LINES		LINE TO GND
	MD6P-24	MD6P-65	
Discharge voltage (peak voltage)	30V min.	70V min.	±160V min.
Max. surge voltage*	40V max.	100V max.	±650V max.
Leakage current	≤5μA @30V DC	≤5μA @70V DC	≤5μA @±160V DC
Max. line voltage [] safety approval	30V DC [28V]	70V DC [66V]	—
Response time	≤4 nsec.	≤4 nsec.	≤20 nsec.
Capacitance	≤2500 pF @1kHz	≤2500 pF @1kHz	≤100 pF @1kHz
Discharge current	10000A (8 / 20 μsec.)		
Max. load current	100mA		
Internal series resist.	approx. 22Ω including return		

*The maximum voltage that could pass through M-RESTER. Protected equipment must be able to withstand this voltage for a very short time period.

STANDARDS & APPROVAL**CE conformity:** ATEX Directive (94/9/EC)

EEx ia EN50020

Category 1G EN50284

Ex d EN60079-1

EMC Directive (89/336/EEC)

EMI EN61000-6-4

EMS EN61000-6-2

Safety approval

FM: Intrinsically safe

Class I, Div. 1, Groups A, B, C and D

Class II, Div. 1, Groups E, F and G

Class III, Div. 1

Class I, Zone 0, AEx ia IIC

T5 and T6

(Class 3610)

FM: Explosion-proof

Class I, Div. 1, Groups B, C and D

Class II, Div. 1, Groups E, F and G

Class III, Div. 1

T6

(Class 3611)

FM: Nonincendive

Class I, Div. 2, Groups A, B, C, and D

Class II, Div. 2, Groups E, F and G

Class III, Div. 1

T6

(Class 3615)

CENELEC: Intrinsically safe (ATEX)

⊕ II 1G, EEx ia IIC; T5 and T6

(EN50020, EN50284)

CENELEC: Flameproof (ATEX)

⊕ II 2G, Ex d IIC; T5 and T6

(EN60079-1)

SAFETY PARAMETERS**Operating temperature:**

T5 -40 to +80°C

T6 -40 to +70°C

-40 to +75°C for CENELEC (ATEX) flameproof

-40 to +80°C for FM explosion-proof

and nonincendive

Ex-data: Ui (Vmax) 30V*

Ii (Imax) 100mA*

Pi 750mW

Ci 2.5 nF

Li 0 mH

* 'Any' for CENELEC intrinsically safe approval (ATEX)

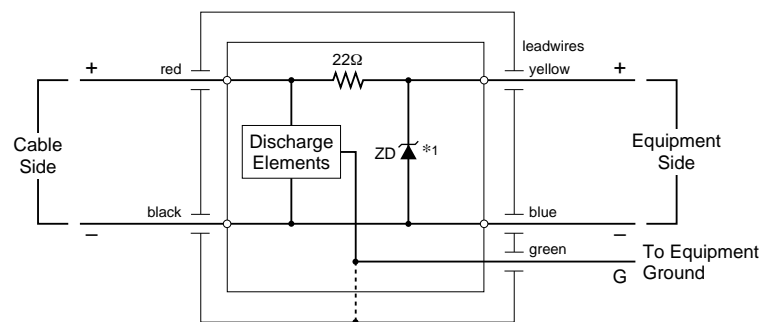
SCHEMATIC CIRCUITRY

*1. The zener diode has polarity. Zero-cross signal cannot be connected.

CONNECTION DIAGRAM & GROUNDING

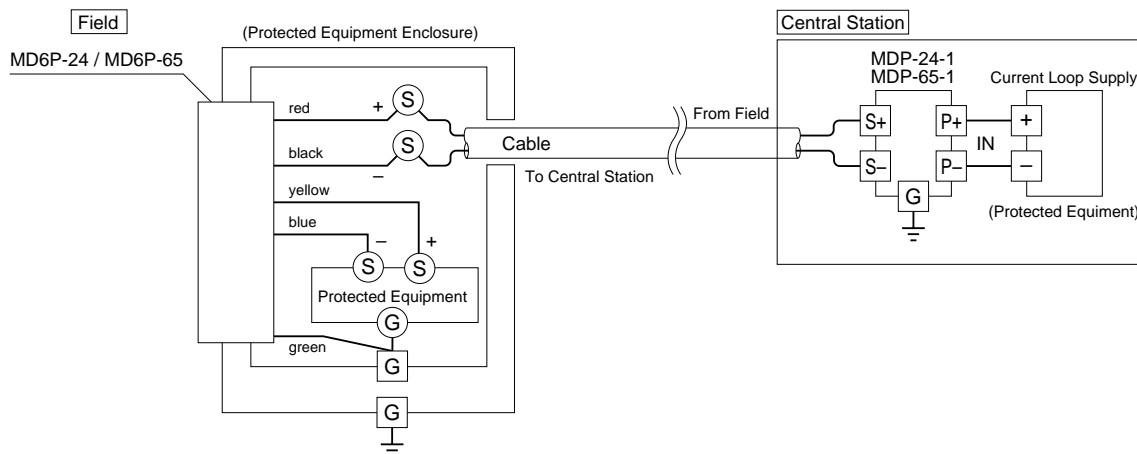

Connect the MD6P's green leadwire to the ground terminal inside the protected equipment enclosure to ground through the enclosure's outside ground terminal.

If the enclosure does not have an inside ground terminal, connect the green leadwire directly to the outside ground wire pulled inside the enclosure. Keep the ground wire as short as possible.

EXTERNAL DIMENSIONS mm (inch)

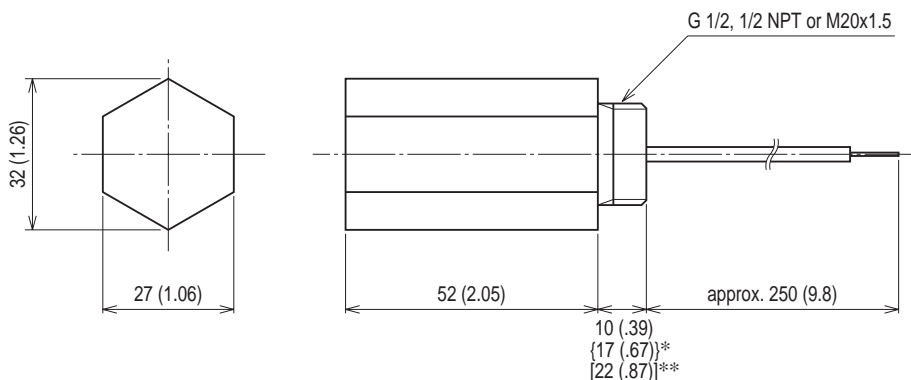

* { } for M20x1.5 with CENECEC (ATEX) flameproof approval
 **[] for 1/2 NPT