

Bargraph Indicators 48N Series

BARGRAPH INDICATING ALARM
(with 2-wire transmitter excitation)

MODEL **48NAVD**

MODEL & SUFFIX CODE SELECTION

48NAVD-□□□-□□

MODEL _____

INPUT _____

4 – 20mA DC

ALARM OUTPUT _____

2 : 2 points

4 : 4 points

BAR LED COLOR _____

R : Red

Y : Amber

G : Green

B : Blue

1 : Multi-color (red, orange and green), Pattern 1 *1

2 : Multi-color (red, orange and green), Pattern 2 *1

*1 : See 'Front Panel Configuration.'

MOUNTING DIRECTION _____

V : Vertical

H : Horizontal

POWER INPUT _____

M : 85 – 264V AC *2

M2: 100 – 240V AC

R : 24V DC

*2 : CE marking not available

OPTIONS _____

/CE: CE marking

/D : Bezels for DIN panel cutout *3

*3 : Bezels for M-System's 48 Series panel cutout will be attached to the product package if Option /D is not specified.

ORDERING INFORMATION

Specify code number and variables.

- **Code number** (e.g. 48NAVD-41V-R/CE/D)
- **Special input range** (For codes Z & 0)
- **Bargraph scale** (e.g. 0 – 100%)
(See 'Scale Plate.')

BEZEL OPTION

Bezels are used to adapt the 48N Series to an existing panel cutout. In order to replace M-System's 48 Series products, use the one attached to the 48N Series as standard. When the existing panel is cut according to DIN standard, specify 'D' suffix code.

For a new installation, no bezel is required. Please refer to 'Mounting Requirement' and mount the 48N directly.

Ingress protection is invalid when the 48N is mounted with a bezel, or when multiple modules are stacked side by side.

RELATED PRODUCTS

- Spare scale plate

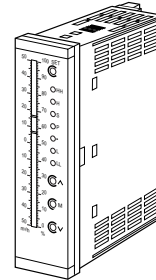

Functions & Features

- Displays a process variable in graphic bargraph of 101 LED segments in proportion to a 2-wire transmitter output
- 2-wire transmitter excitation
- Usable with a smart transmitter
- Provides max. 4 alarm contact outputs
- Multi-color indicator
- IP 65 front cover
- Scale plate is easily replaced
- Separable terminal block

GENERAL SPECIFICATIONS

Construction: Panel flush mounting

Connection: M3 screw terminals
(nickel plated steel; torque 0.6 N·m)

Material

Housing: Flame resistant resin (black)

Scale plate: Flame resistant resin (white scale & characters on black base)

Bargraph: 101-segment LED, 100 mm (3.96") long, 3.00 mm (.12") wide

Scale

Characters: Max. 4 characters including decimal point and negative sign

Divisions: Min. 22, max. 100

Engineering unit: Max. 6 characters

Setpoint adjustment

48NAVD-2: H [L setpoint] to 100%
L 0 to [H setpoint]
or No alarm trip

48NAVD-4: HH [H setpoint] to 100%
H [L setpoint] to [HH setpoint]
L [LL setpoint] to [H setpoint]
LL 0 to [L setpoint]
or No alarm trip

Alarm deadband (hysteresis): 1%

Zero & span adjustments: ±10%

Isolation: Input to output to power

INPUT & OUTPUT

■ SUPPLY OUTPUT (across the terminals 3 – 4)

Output voltage: 24 – 28V DC with no load
18V DC maximum at 20mA

Current rating: 22mA DC maximum

• Shortcircuit Protection

Current limited: 30mA maximum

Protected time duration: No limit

■ **INPUT:** 4 – 20mA DC; input resistor incorporated (2W)

Input resistance: 250Ω

■ ALARM OUTPUT

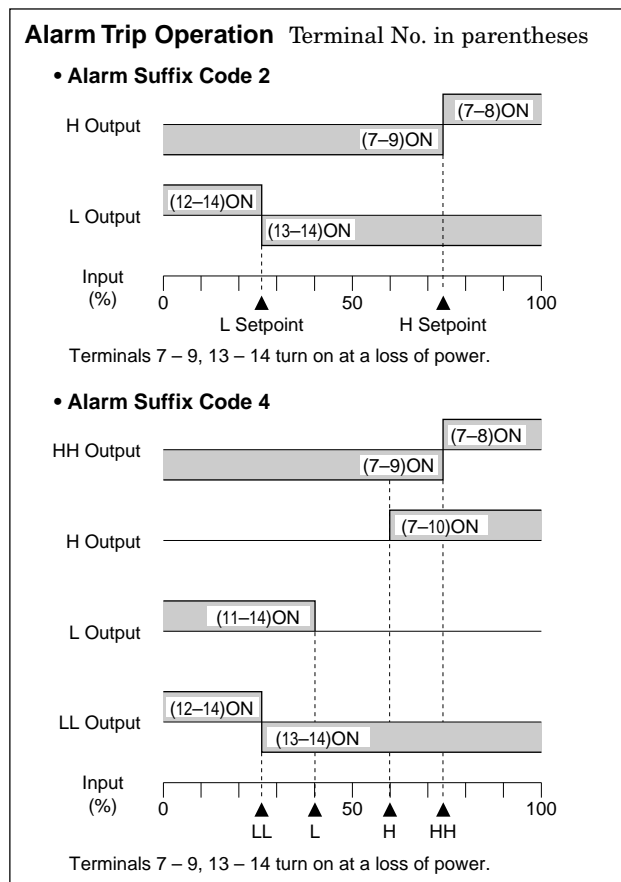

• **Relay Contact:** 250V AC @1A ($\cos\phi=1$)
30V DC @5A (resistive load)
Electrical life $\geq 3 \times 10^4$ cycles (rate 6/min.)

Maximum switching voltage: 250V AC or 220V DC

Maximum switching power: 380VA or 150W
(resistive load)

Minimum load: 5V DC @100mA

Mechanical life: $\geq 5 \times 10^8$ cycles (rate 180/min.)

INSTALLATION

Power input

AC: Operational voltage range 85 – 264V,
47 – 66 Hz,

approx. 5VA at 100V with max. load
approx. 7VA at 200V with max. load

approx. 7.5VA at 264V with max. load

DC: 24V $\pm 15\%$ (ripple 10% p-p max.)

approx. 3W at 20.4V with max. load

approx. 3W at 24V with max. load

approx. 3.5W at 27.6V with max. load

Operating temperature: -5 to +55°C (23 to 131°F)

Operating humidity: 30 to 90% RH (non-condensing)

Front panel ingress protection: IP 65*

*Single mounting according to the specified panel cutout

Mounting: Panel flush mounting

Panel cutout: 31.5×138 mm (1.24"×5.43")

Panel thickness: 1.6 – 8.0 mm (0.06" – 0.31")

Dimensions

Vertical mounting: W36×H144×D103 mm
(1.42"×5.67"×4.06")

Horizontal mounting: W144×H36×D103 mm
(5.67"×1.42"×4.06")

Weight: 300 g (0.66 lbs)

PERFORMANCE in percentage of span

Accuracy: $\pm 1\%$ ± 1 digit

Temp. coefficient: $\pm 0.015\%$ of FS/°C

($\pm 0.008\%$ of FS/°F)

Response time: ≤ 0.5 seconds

Insulation resistance: $\geq 100M\Omega$ with 500V DC

(input to output to power)

Dielectric strength: 2000V AC @1 minute (input to

power or ground, power to ground,

output to input or power or ground)

STANDARDS & APPROVALS

CE conformity: EMC Directive (89/336/EEC)

EMI EN61000-6-4

EMS EN61000-6-2

Low Voltage Directive (2006/95/EC)

EN61010-1

Installation category II

Pollution degree 2

Max. operating voltage 300V

Input to output to power – Reinforced insulation

SCHEMATIC CIRCUITRY & CONNECTION DIAGRAM

■ALARM SUFFIX CODE 2: 2 points

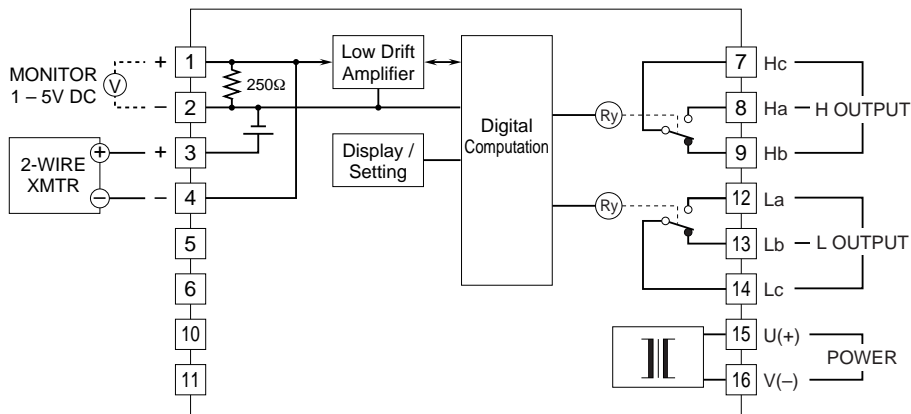

■ALARM SUFFIX CODE 4: 4 points

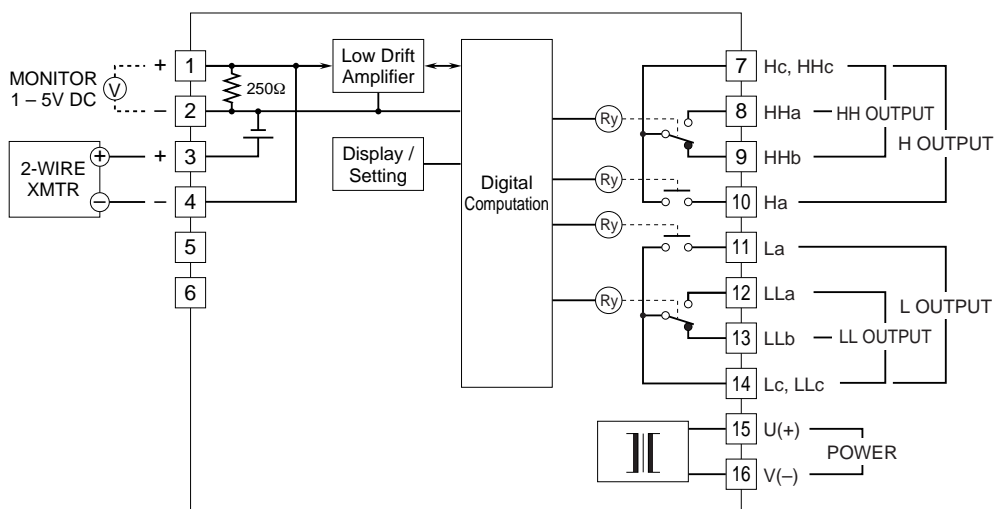

■Relay Protection •AC Powered

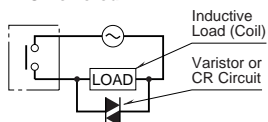

•DC Powered

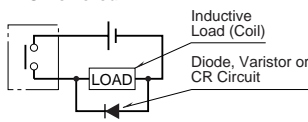

■4 - 20mA Input without Excitation

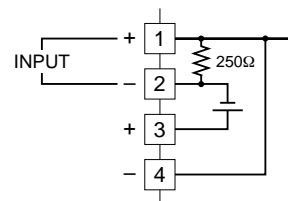

SCALE PLATE

WHAT MUST BE SPECIFIED WHEN ORDERING

Please specify the bargraph scale range and engineering unit. Number of divisions, division line length, character font are determined by M-System.

[Example] : Bargraph range 0 to 300 cm
 Bargraph scale range: 0 – 300
 Engineering unit for the bargraph: cm

TYPES OF DIVISIONS

Five (5) types of divisions are used depending upon the scale span, which determined by the following equation:

$$\text{Scale Span} = (\text{Max. range value} - \text{Min. range value}) \times 10^n$$

where n = integer (used to limit the calculated scale span to the minimum of 1.1, below 11.0.)

Type 1: 1.1 ≤ Scale Span < 1.3

Number of divisions: 22 to 25.9

Scale: Starts at 0, increments in 0.02 / 0.2 / 2 / 20 / 200. Min. and max. values are indicated.
 4 digits including negative sign and decimal point.

Division lines: Long, Short, Medium, Short, Long
 (4 division lines repeating)

Minimum Divisions	Maximum Divisions	Bipolar Scale
11	1.29	600
10	1.2	400
8	1.0	200
6	0.8	0
4	0.6	-200
2	0.4	-400
0	0.2	-600

Type 3: 2.0 ≤ Scale Span < 2.6

Number of divisions: 40 to 51.9

Scale: Starts at 0, increments in 0.05 / 0.5 / 5 / 50 / 500. Min. and max. values are indicated.
 4 digits including negative sign and decimal point.

Division lines: Long, Short, Medium, Short, Medium, Short, Medium, Short, Medium, Short, Long
 (10 divisions repeating)

Minimum Divisions	Maximum Divisions	Bipolar Scale
20	2.59	120
15	2.5	100
10	2.0	50
5	1.5	0
0	1.0	-50
	0.5	-100
	0	-120

Type 2: 1.3 ≤ Scale Span < 2.0

Number of divisions: 26 to 39.9

Scale: Starts at 0, increments in 0.03 / 0.3 / 3 / 30 / 300. Min. and max. values are indicated.
 4 digits including negative sign and decimal point.

Division lines: Long, Short, Medium, Short, Medium, Short, Long (6 divisions repeating)

Minimum Divisions	Maximum Divisions	Bipolar Scale
130	1.99	0.8
120	1.8	0.6
90	1.5	0.3
60	1.2	0.0
30	0.9	-0.3
0	0.6	-0.6
	0.3	-0.8
	0.0	

Type 4: 2.6 ≤ Scale Span < 5.5

Number of divisions: 26 to 39.9

Scale: Starts at 0, increments in 0.05 / 0.5 / 5 / 50 / 500. Min. and max. values are indicated.
 4 digits including negative sign and decimal point.

Division lines: Long, Medium, Medium, Medium, Medium, Long (5 divisions repeating)

Minimum Divisions	Maximum Divisions	Bipolar Scale
260	5.49	250
250	5	200
200	4.5	150
150	4	100
100	3.5	50
50	3	0
0	2.5	-50
	2	-100
	1.5	-150
	1	-200
	0.5	-250
	0	

Specifications subject to change without notice.

• **Type 5: $5.5 \leq \text{Scale Span} < 11.0$**

Number of divisions: 27.5 to 54.9

Scale: Starts at 0, increments in 0.01 / 0.1 / 1 / 10 / 100 / 1000. Min. and max. values are indicated. 4 digits including negative sign and decimal point.

Division lines: Long, Medium, Medium, Medium, Medium, Long (5 divisions repeating)

Minimum Divisions	Maximum Divisions	Bipolar Scale
550 =	10.9 =	0.5 =
500 =	10.0 =	0.4 =
=	9.0 =	0.3 =
=	8.0 =	0.2 =
400 =	7.0 =	0.1 =
=	6.0 =	0 =
=	5.0 =	-0.1 =
300 =	4.0 =	-0.2 =
=	3.0 =	-0.3 =
=	2.0 =	-0.4 =
100 =	1.0 =	-0.5 =
=	0.0 =	
0 =		

[Example] : Bargraph range 0 to 300 cm (Type 4)

- Left scale range: 0 – 300

- Left scale unit (bargraph): cm

- Right scale: None

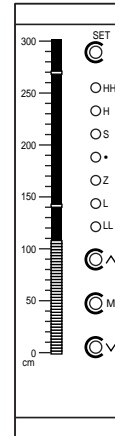

FRONT PANEL CONFIGURATION

■ALARM SUFFIX CODE 2: 2 points

• Vertical Mounting

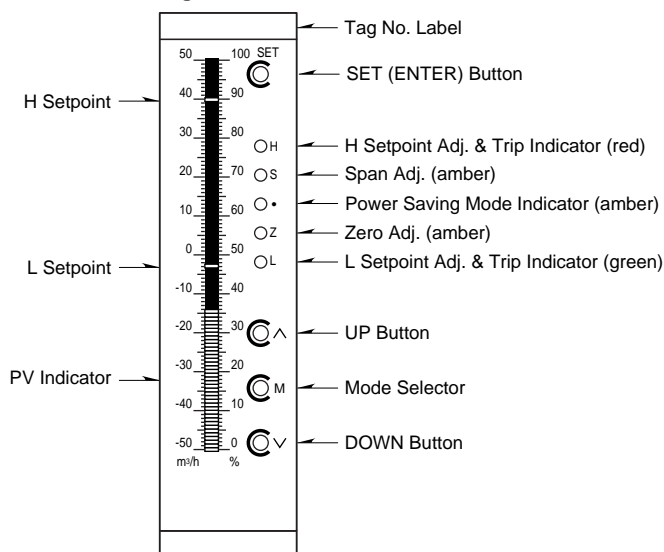

• Horizontal Mounting

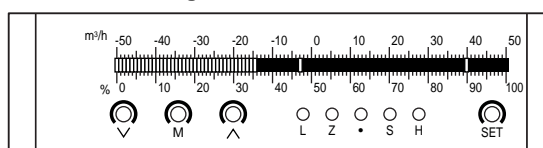

■ALARM SUFFIX CODE 4: 4 points

• Vertical Mounting

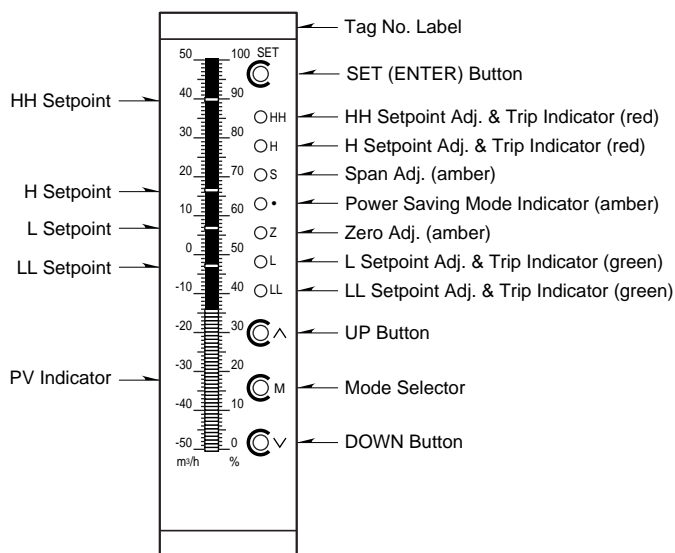

• Horizontal Mounting

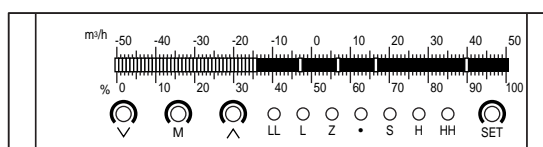

• Bar Color Patterns

Pattern 1 (model suffix code 1)

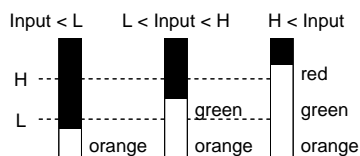

Pattern 2 (model suffix code 2)

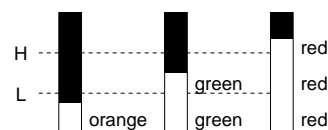

Specifications subject to change without notice.

EXTERNAL DIMENSIONS & TERMINAL ASSIGNMENT mm (inch)

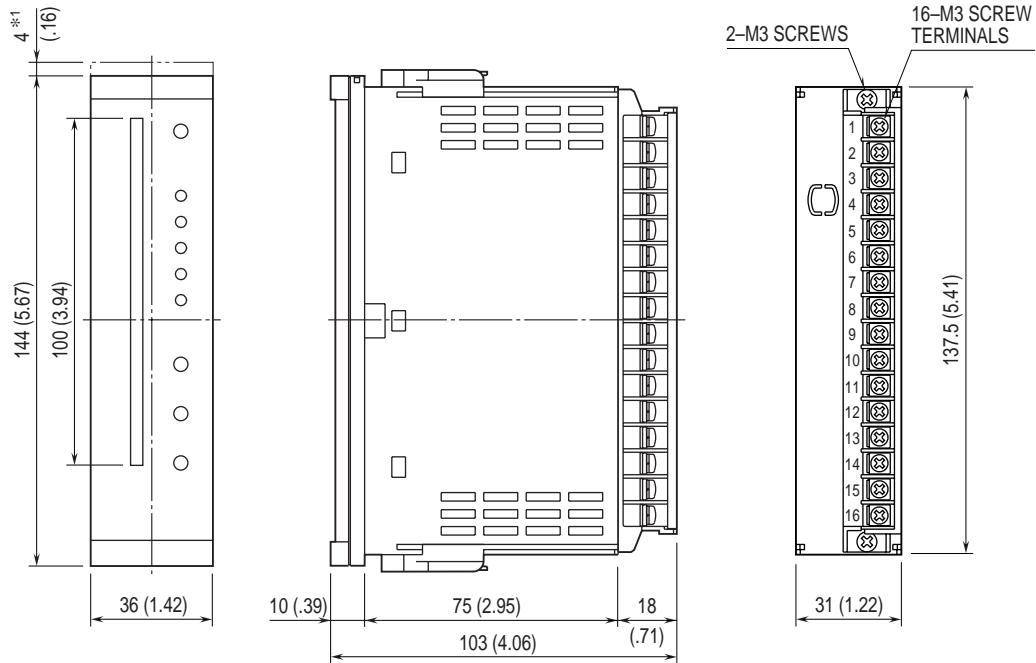

■ STANDARD BEZEL *2

■ OPTION /D BEZEL *3

Rounded corners for the option /D

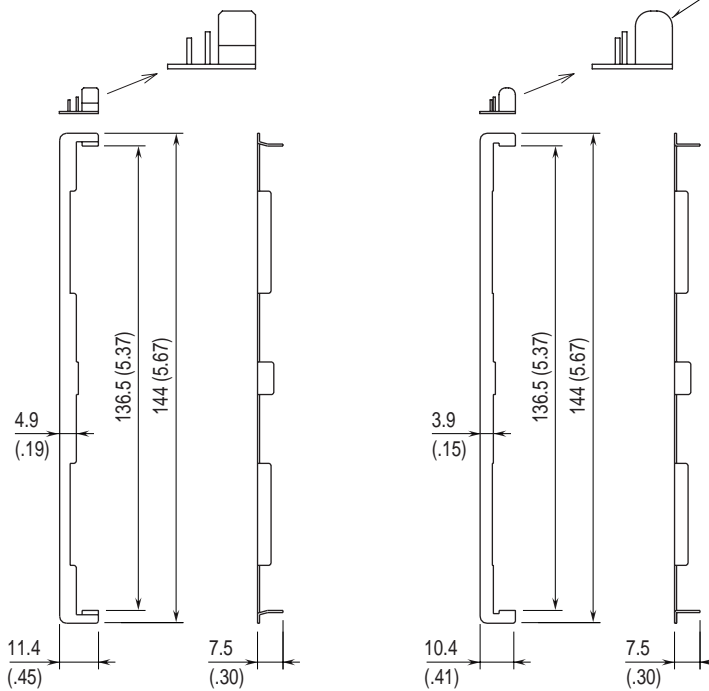

*1. Space required when replacing the scale plate.
 *2. Used for the existing panel cutout of M-System 48 Series (38 × 139.5 mm).
 *3. Used for the existing DIN panel cutout (33 × 138 mm)

PANEL CUTOUT unit: mm

■ **SINGLE MOUNTING (ingress protection)**

• **Vertical Mounting**

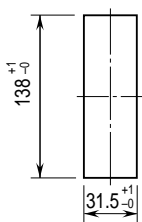

Panel thickness: 1.6 – 8.0 mm

• **Horizontal Mounting**

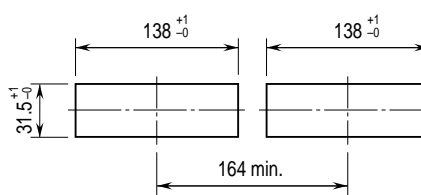

Panel thickness: 1.6 – 8.0 mm

■ **CLUSTERED MOUNTING (no ingress protection)**

• **Vertical Mounting**

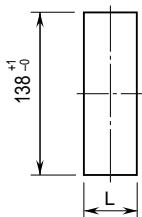

Panel thickness: 1.6 – 8.0 mm

$L = \{31.5 + 36 \times (N - 1)\}^{+1}_{-0}$
(N : number of units)

• **Horizontal Mounting**

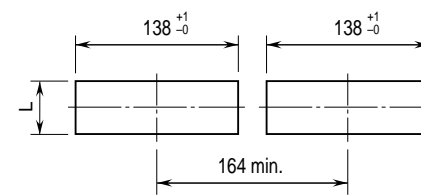

Panel thickness: 1.6 – 8.0 mm

$L = \{31.5 + 36 \times (N - 1)\}^{+1}_{-0}$
(N : number of units)

Note 1. Observe at the minimum of 3 cm above and below the units for heat dissipation.
Note 2. No bezel is needed when the panel is cut according to the above drawings.

ADJUSTMENT PROCEDURE

■ **ZERO ADJUSTMENT:** Apply 0% input signal before adjustment.

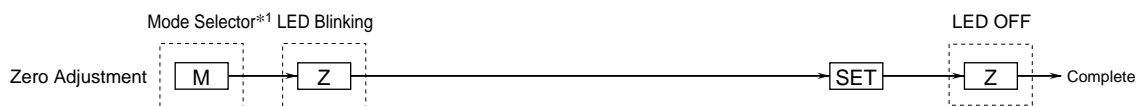

■ **SPAN ADJUSTMENT:** Apply 100% input signal before adjustment.



■ **ALARM SETTING:** Proceed after the zero / span adjustments.

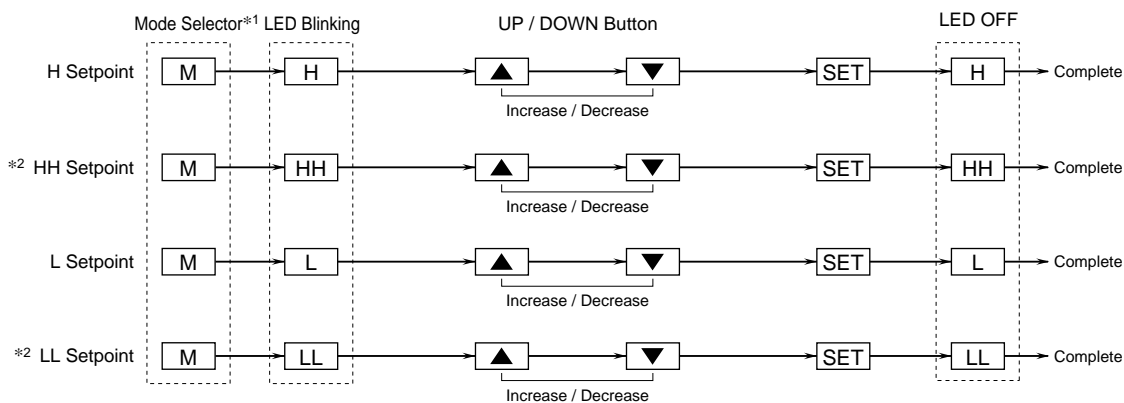

■ **POWER SAVING MODE**

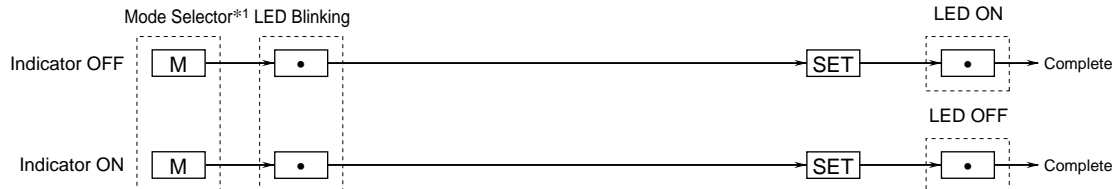

*1. Keep pressing at least for 3 seconds to activate Mode Selector M. Press briefly for second and more times within 1 minute after it has been activated.

*2. HH or LL setpoints are not provided for the 48NAVD-2.

Each setting sequence is complete only when SET button is pressed. Once set, parameters are not lost even after the power is removed, except for the power saving mode. The power saving mode is automatically cancelled when the power is reset.